

# OPERATION AND PARTS MANUAL



## **WHISPERWATT™ SERIES MODEL DCA400SSI 60HZ GENERATOR (ISUZU 6WG1X DIESEL ENGINE)**

**PARTS LIST NO. C3871301004**

Revision #2 (11/03/08)

To find the latest revision of this  
publication, visit our website at:  
[www.mqpower.com](http://www.mqpower.com)



**THIS MANUAL MUST ACCOMPANY THE EQUIPMENT AT ALL TIMES.**



**CALIFORNIA — Proposition 65 Warning**

Diesel engine exhaust and some of its constituents are known to the State of California to cause cancer, birth defects and other reproductive harm.

## REPORTING SAFETY DEFECTS

---

If you believe that your vehicle has a defect that could cause a crash or could cause injury or death, you should immediately inform the National Highway Traffic Safety Administration (NHTSA) in addition to notifying Multiquip at 1-800-421-1244.

If NHTSA receives similar complaints, it may open an investigation, and if it finds that a safety defect exists in a group of vehicles, it may order a recall and remedy campaign. However, NHTSA cannot become involved in individual problems between you, your dealer, or Multiquip.

To contact NHTSA, you may either call the Vehicle Safety Hotline toll-free at 1-888-327-4236 (TTY: 1-800-424-9153), go to <http://www.nhtsa.dot.gov>; or write to:

Administrator  
NHTSA  
1200 New Jersey Avenue S.E.  
Washington, DC 20590

You can also obtain information about motor vehicle safety from <http://www.safecar.gov>.

# TABLE OF CONTENTS

## DCA400SSI GENERATOR

Proposition 65 Warning .....	2
Reporting Safety Defects.....	3
Table Of Contents .....	4
Parts Ordering Procedures.....	5
Safety Information .....	6-11
Specifications .....	12
Dimensions.....	13
Installation .....	14-15
General Information.....	16
Major Components .....	17
Generator Control Panel.....	18-19
Engine Operating Panel.....	20
Output Terminal Panel Familiarization .....	22-24
Load Application .....	25
Generator Outputs.....	26-27
Gauge Reading .....	27
Output Terminal Panel Connections .....	28-29
Inspection/Setup.....	30-33
Generator Start-Up Procedure (Manual) .....	34-35
Generator Start-Up Procedure (Auto Mode).....	36
Generator Shut-Down Procedures .....	37
Maintenance .....	38-41
Trailer Maintenance .....	42-45
Trailer Wiring Diagram .....	46
Generator Wiring Diagram.....	47
Engine Wiring Diagram.....	48
Controller Wiring Diagram .....	49
Troubleshooting (Generator).....	50
Troubleshooting (Engine Controller) .....	51
Troubleshooting (Diagnostic Lamp) .....	52
Explanation Of Code In Remarks Column .....	54
Suggested Spare Parts .....	55

## Component Drawings

Generator Assembly .....	56-59
Engine Operating Panel Assembly .....	60-61
Control Box Assembly .....	62-67
Engine And Radiator Assembly.....	68-71
Output Terminal Assembly .....	72-73
Battery Assembly.....	74-77
Fuel Tank Assembly (S/N 3813334 & Below) ...	78-79
Fuel Tank Assembly (S/N 3813335 & Above) ...	80-81
Enclosure #1 Assembly .....	82-83
Enclosure #2 Assembly .....	84-85
Enclosure #3 Assembly .....	86-89
Rubber Seals Assembly .....	90-91
Nameplate And Decals Assembly .....	92-95

Terms And Conditions Of Sale — Parts .....	96
--	----

### NOTICE

Specifications and part numbers are subject to change without notice.

# PARTS ORDERING PROCEDURES

## Ordering parts has never been easier! Choose from three easy options:

Effective:  
January 1<sup>st</sup>, 2006

www.mqpower.com



### Order via Internet (Dealers Only):

Order parts on-line using Multiquip's SmartEquip website!

- View Parts Diagrams
- Order Parts
- Print Specification Information



If you have an MQ Account, to obtain a Username and Password, E-mail us at: [parts@multiquip.com](mailto:parts@multiquip.com).

To obtain an MQ Account, contact your District Sales Manager for more information.

Goto [www.multiquip.com](http://www.multiquip.com) and click on **Order Parts** to log in and save!

Use the **internet** and qualify for a **5% Discount** on *Standard orders* for all orders which include complete part numbers.\*

Note: Discounts Are Subject To Change



### Order via Fax (Dealers Only):

All customers are welcome to order parts via Fax.

**Domestic (US) Customers dial:**  
1-800-6-PARTS-7 (800-672-7877)

**Fax** your order in and qualify for a **2% Discount** on *Standard orders* for all orders which include complete part numbers.\*

Note: Discounts Are Subject To Change



**Order via Phone: Domestic (US) Dealers Call:**  
1-800-427-1244

### Non-Dealer Customers:

Contact your local Multiquip Dealer for parts or call 800-427-1244 for help in locating a dealer near you.



**International Customers** should contact their local Multiquip Representatives for Parts Ordering information.

## When ordering parts, please supply:

- |   |  |
|---|--|
| <input type="checkbox"/> Dealer Account Number                                | <input type="checkbox"/> Specify Preferred Method of Shipment: |
| <input type="checkbox"/> Dealer Name and Address                              | ✓ UPS/Fed Ex                      ✓ DHL                        |
| <input type="checkbox"/> Shipping Address (if different than billing address) | ■ Priority One                      ✓ Truck                    |
| <input type="checkbox"/> Return Fax Number                                    | ■ Ground   |
| <input type="checkbox"/> Applicable Model Number                              | ■ Next Day   |
| <input type="checkbox"/> Quantity, Part Number and Description of Each Part   | ■ Second/Third Day   |

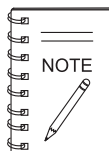

All orders are treated as *Standard Orders* and will ship the same day if received prior to 3PM PST.

WE ACCEPT ALL MAJOR CREDIT CARDS!



# SAFETY INFORMATION

Do not operate or service the equipment before reading the entire manual. Safety precautions should be followed at all times when operating this equipment. Failure to read and understand the safety messages and operating instructions could result in injury to yourself and others.

## SAFETY MESSAGES

The four safety messages shown below will inform you about potential hazards that could injure you or others. The safety messages specifically address the level of exposure to the operator and are preceded by one of four words: **DANGER**, **WARNING**, **CAUTION** or **NOTICE**.

## SAFETY SYMBOLS

**⚠ DANGER**

Indicates a hazardous situation which, if not avoided, **WILL** result in **DEATH** or **SERIOUS INJURY**.

**⚠ WARNING**

Indicates a hazardous situation which, if not avoided, **COULD** result in **DEATH** or **SERIOUS INJURY**.







**⚠ CAUTION**

Indicates a hazardous situation which, if not avoided, **COULD** result in **MINOR** or **MODERATE INJURY**.

**NOTICE**

Addresses practices not related to personal injury.

Potential hazards associated with the operation of this equipment will be referenced with hazard symbols which may appear throughout this manual in conjunction with safety messages.

Symbol	Safety Hazard
	Lethal exhaust gas hazards
	Explosive fuel hazards
	Burn hazards
	Overspeed hazards
	Rotating parts hazards
	Pressurized fluid hazards
	Electric shock hazards

# SAFETY INFORMATION

## GENERAL SAFETY

### CAUTION

- **NEVER** operate this equipment without proper protective clothing, shatterproof glasses, respiratory protection, hearing protection, steel-toed boots and other protective devices required by the job or city and state regulations.



- **NEVER** operate this equipment when not feeling well due to fatigue, illness or when under medication.



- **NEVER** operate this equipment under the influence of drugs or alcohol.



### NOTICE

- This equipment should only be operated by trained and qualified personnel 18 years of age and older.
- Whenever necessary, replace nameplate, operation and safety decals when they become difficult to read.
- Manufacturer does not assume responsibility for any accident due to equipment modifications. Unauthorized equipment modification will void all warranties.
- **NEVER** use accessories or attachments that are not recommended by Multiquip for this equipment. Damage to the equipment and/or injury to user may result.
- **ALWAYS** know the location of the nearest **fire extinguisher**.
- **ALWAYS** know the location of the nearest **first aid kit**.
- **ALWAYS** know the location of the nearest phone or **keep a phone on the job site**. Also, know the phone numbers of the nearest **ambulance, doctor and fire department**. This information will be invaluable in the case of an emergency.



## GENERATOR SAFETY

### DANGER

- The engine fuel exhaust gases contain poisonous carbon monoxide. This gas is colorless and odorless, and can cause death if inhaled.
- The engine of this equipment requires an adequate free flow of cooling air. **NEVER** operate this equipment in any enclosed or narrow area where free flow of the air is restricted. If the air flow is restricted it will cause injury to people and property and serious damage to the equipment or engine.

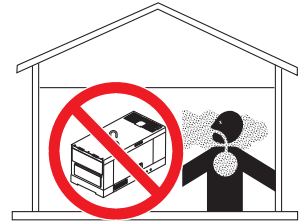

- **NEVER** operate the equipment in an explosive atmosphere or near combustible materials. An explosion or fire could result causing severe **bodily harm or even death**.



### WARNING

- **NEVER** disconnect any **emergency or safety devices**. These devices are intended for operator safety. Disconnection of these devices can cause severe injury, bodily harm or even death. Disconnection of any of these devices will void all warranties.

### CAUTION

- **NEVER** lubricate components or attempt service on a running machine.



### NOTICE

- **ALWAYS** ensure generator is on level ground before use.
- **ALWAYS** keep the machine in proper running condition.
- Fix damage to machine and replace any broken parts immediately.
- **ALWAYS** store equipment properly when it is not being used. Equipment should be stored in a clean, dry location out of the reach of children and unauthorized personnel.

# SAFETY INFORMATION

## ENGINE SAFETY

### WARNING

- **DO NOT** place hands or fingers inside engine compartment when engine is running.
- **NEVER** operate the engine with heat shields or guards removed.
- Keep fingers, hands hair and clothing away from all moving parts to prevent injury. 
- **DO NOT** remove the radiator cap while the engine is hot. High pressure boiling water will gush out of the radiator and severely scald any persons in the general area of the generator.
- **DO NOT** remove the coolant drain plug while the engine is hot. Hot coolant will gush out of the coolant tank and severely scald any persons in the general area of the generator. 
- **DO NOT** remove the engine oil drain plug while the engine is hot. Hot oil will gush out of the oil tank and severely scald any persons in the general area of the generator.

### CAUTION

- **NEVER** touch the hot exhaust manifold, muffler or cylinder. Allow these parts to cool before servicing equipment. 

### NOTICE

- **NEVER** run engine without an air filter or with a dirty air filter. Severe engine damage may occur. Service air filter frequently to prevent engine malfunction.
- **NEVER** tamper with the factory settings of the engine or engine governor. Damage to the engine or equipment can result if operating in speed ranges above the maximum allowable. 

- Wet stacking is a common problem with diesel engines which are operated for extended periods with light or no load applied. When a diesel engine operates without sufficient load (less than 40% of the rated output), it will not operate at its optimum temperature. This will allow unburned fuel to accumulate in the exhaust system, which can foul the fuel injectors, engine valves and exhaust system, including turbochargers, and reduce the operating performance.

In order for a diesel engine to operate at peak efficiency, it must be able to provide fuel and air in the proper ratio and at a high enough engine temperature for the engine to completely burn all of the fuel.

Wet stacking does not usually cause any permanent damage and can be alleviated if additional load is applied to relieve the condition. It can reduce the system performance and increase maintenance. Applying an increasing load over a period of time until the excess fuel is burned off and the system capacity is reached usually can repair the condition. This can take several hours to burn off the accumulated unburned fuel.

- State Health Safety Codes and Public Resources Codes specify that in certain locations, spark arresters must be used on internal combustion engines that use hydrocarbon fuels. A spark arrester is a device designed to prevent accidental discharge of sparks or flames from the engine exhaust. Spark arresters are qualified and rated by the United States Forest Service for this purpose. In order to comply with local laws regarding spark arresters, consult the engine distributor or the local Health and Safety Administrator.



# SAFETY INFORMATION

## FUEL SAFETY

### DANGER

- **DO NOT** start the engine near spilled fuel or combustible fluids. Diesel fuel is extremely flammable and its vapors can cause an explosion if ignited.
- **ALWAYS** refuel in a well-ventilated area, away from sparks and open flames.
- **ALWAYS** use extreme caution when working with **flammable** liquids.
- **DO NOT** fill the fuel tank while the engine is running or hot.
- **DO NOT** overfill tank, since spilled fuel could ignite if it comes into contact with hot engine parts or sparks from the ignition system.
- Store fuel in appropriate containers, in well-ventilated areas and away from sparks and flames.
- **NEVER** use fuel as a cleaning agent.
- **DO NOT** smoke around or near the equipment. Fire or explosion could result from fuel vapors or if fuel is spilled on a hot engine.



## TOWING SAFETY

### CAUTION

- Check with your local county or state safety towing regulations, in addition to meeting **Department of Transportation (DOT) Safety Towing Regulations**, before towing your generator.
- Refer to MQ Power trailer manual for additional safety information.
- In order to reduce the possibility of an accident while transporting the generator on public roads, **ALWAYS** make sure the trailer that supports the generator and the towing vehicle are mechanically sound and in good operating condition.
- **ALWAYS** shutdown engine before transporting



- Make sure the hitch and coupling of the towing vehicle are rated equal to, or greater than the trailer “gross vehicle weight rating.”
- **ALWAYS** inspect the hitch and coupling for wear. **NEVER** tow a trailer with defective hitches, couplings, chains, etc.
- Check the tire air pressure on both towing vehicle and trailer. **Trailer tires should be inflated to 50 psi cold.** Also check the tire tread wear on both vehicles.
- **ALWAYS** make sure the trailer is equipped with a **safety chain**.
- **ALWAYS** properly attach trailer’s safety chains to towing vehicle.
- **ALWAYS** make sure the vehicle and trailer directional, backup, brake and trailer lights are connected and working properly.
- DOT Requirements include the following:
  - Connect and test electric brake operation.
  - Secure portable power cables in cable tray with tie wraps.
- The maximum speed for highway towing is **55 MPH** unless posted otherwise. Recommended off-road towing is not to exceed **15 MPH** or less depending on type of terrain.
- Avoid sudden stops and starts. This can cause skidding, or jack-knifing. Smooth, gradual starts and stops will improve towing.
- Avoid sharp turns to prevent rolling.
- Trailer should be adjusted to a level position at all times when towing.
- Raise and lock trailer wheel stand in up position when towing.
- Place **chock blocks** underneath wheel to prevent **rolling** while parked.
- Place **support blocks** underneath the trailer’s bumper to prevent **tipping** while parked.
- Use the trailer’s swivel jack to adjust the trailer height to a level position while parked.

# SAFETY INFORMATION

## ELECTRICAL SAFETY

### DANGER

- **DO NOT** touch output terminals during operation. Contact with output terminals during operation can cause **electrocution, electrical shock or burn.**

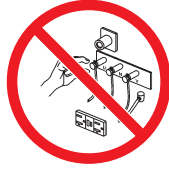

- The electrical voltage required to operate the generator can cause severe injury or even death through physical contact with live circuits. Turn generator and all circuit breakers **OFF** before performing maintenance on the generator or making contact with output terminals.

- **NEVER** insert any objects into the output receptacles during operation. This is extremely dangerous. The possibility exists of **electrical shock, electrocution or death.**



- Backfeed to a utility system can cause **electrocution** and/or property damage. **NEVER** connect the generator to a building's electrical system without a transfer switch or other approved device. All installations should be performed by a **licensed electrician** in accordance with all applicable laws and electrical codes. Failure to do so could result in electrical shock or burn, causing **serious injury or even death.**



## Power Cord/Cable Safety

### DANGER

- **NEVER** let power cords or cables **lay in water.**
- **NEVER stand in water** while AC power from the generator is being transferred to a load.
- **NEVER** use **damaged** or **worn** cables or cords when connecting equipment to generator. Inspect for cuts in the insulation.
- **NEVER** grab or touch a live power cord or cable with wet hands. The possibility exists of **electrical shock, electrocution or death.**

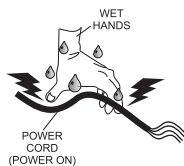

- Make sure power cables are securely connected to the generator's output receptacles. Incorrect connections may cause electrical shock and damage to the generator.

### NOTICE

- **ALWAYS** make certain that proper power or extension cord has been selected for the job. See Cable Selection Chart in this manual.

## Grounding Safety

### DANGER

- **ALWAYS** make sure that electrical circuits are properly grounded to a suitable earth ground (ground rod) per the National Electrical Code (NEC) and local codes before operating generator. **Severe injury or death by electrocution** can result from operating an ungrounded generator.
- **NEVER** use gas piping as an electrical ground.

# SAFETY INFORMATION

## BATTERY SAFETY

### DANGER

- **DO NOT** drop the battery. There is a possibility that the battery will explode.
- **DO NOT** expose the battery to open flames, sparks, cigarettes, etc. The battery contains combustible gases and liquids. If these gases and liquids come into contact with a flame or spark, an explosion could occur.



### WARNING

- **ALWAYS** wear safety glasses when handling the battery to avoid eye irritation. The battery contains acids that can cause injury to the eyes and skin.
- Use well-insulated gloves when picking up the battery.
- **ALWAYS** keep the battery charged. If the battery is not charged, combustible gas will build up.
- **ALWAYS** recharge the battery in a well-ventilated environment to avoid the risk of a dangerous concentration of combustible gasses.
- If the battery liquid (dilute sulfuric acid) comes into contact with **clothing or skin**, rinse skin or clothing immediately with plenty of water.
- If the battery liquid (dilute sulfuric acid) comes into contact with **eyes**, rinse eyes immediately with plenty of water and contact the nearest doctor or hospital to seek medical attention.



### CAUTION

- **ALWAYS** disconnect the **NEGATIVE battery terminal** before performing service on the generator.
- **ALWAYS** keep battery cables in good working condition. Repair or replace all worn cables.

## ENVIRONMENTAL SAFETY

### NOTICE

- Dispose of hazardous waste properly. Examples of potentially hazardous waste are used motor oil, fuel and fuel filters.
- **DO NOT** use food or plastic containers to dispose of hazardous waste.
- **DO NOT** pour waste, oil or fuel directly onto the ground, down a drain or into any water source.

# SPECIFICATIONS

<b>Table 1. Generator Specifications</b>	
<b>Model</b>	DCA400SSI
<b>Type</b>	Revolving field, self ventilated, open protected type synchronous generator
<b>Armature Connection</b>	<b>Star with Neutral</b>
<b>Phase</b>	3
<b>Standby Output</b>	440 KVA (352 KW)
<b>Prime Output</b>	400 KVA (320 KW)
<b>Voltage — 1Ø</b>	120,127,139, 240, 254 and 277V
<b>Voltage — 3Ø</b>	208, 220, 240, 416, 440 and 480V
<b>Frequency</b>	60 Hz
<b>Speed</b>	1800 rpm
<b>Power Factor</b>	0.8
<b>Aux. AC Power</b>	Single Phase, 60 Hz
<b>Aux. Voltage/Output</b>	4.8 Kw (2.4 kW x 2)
<b>Dry Weight</b>	11,640 lbs. (5,280 kg.)
<b>Wet Weight</b>	12,875 lbs. (5,840 kg.)
<b>Table 2. Engine Specifications</b>	
<b>Model</b>	ISUZU 6WG1X
<b>Type</b>	4 cycle, water-cooled, direct injection, turbo-charged with air to air after cooler
<b>No. of Cylinders</b>	6 cylinders
<b>Bore x Stroke</b>	5.79 in. x 6.06 in. (147 mm x 154 mm)
<b>Displacement</b>	957 cu. in. (15,681 cc)
<b>Rated Output</b>	464 HP at 1800 rpm
<b>Starting</b>	Electric 24 VDC
<b>Coolant Capacity</b>	15.8 gal. (60.0 liters)
<b>Lube Oil Capacity</b>	14.4 gal. (55.0 liters)
<b>Fuel Type</b>	#2 Diesel Fuel
<b>Fuel Tank Capacity</b>	129 gal. (490 liters)
<b>Fuel Consumption</b>	23.0 gal. (87.3 L)/hr at <b>full load</b>
<b>Battery</b>	12V-200 Ah x 2

# DIMENSIONS

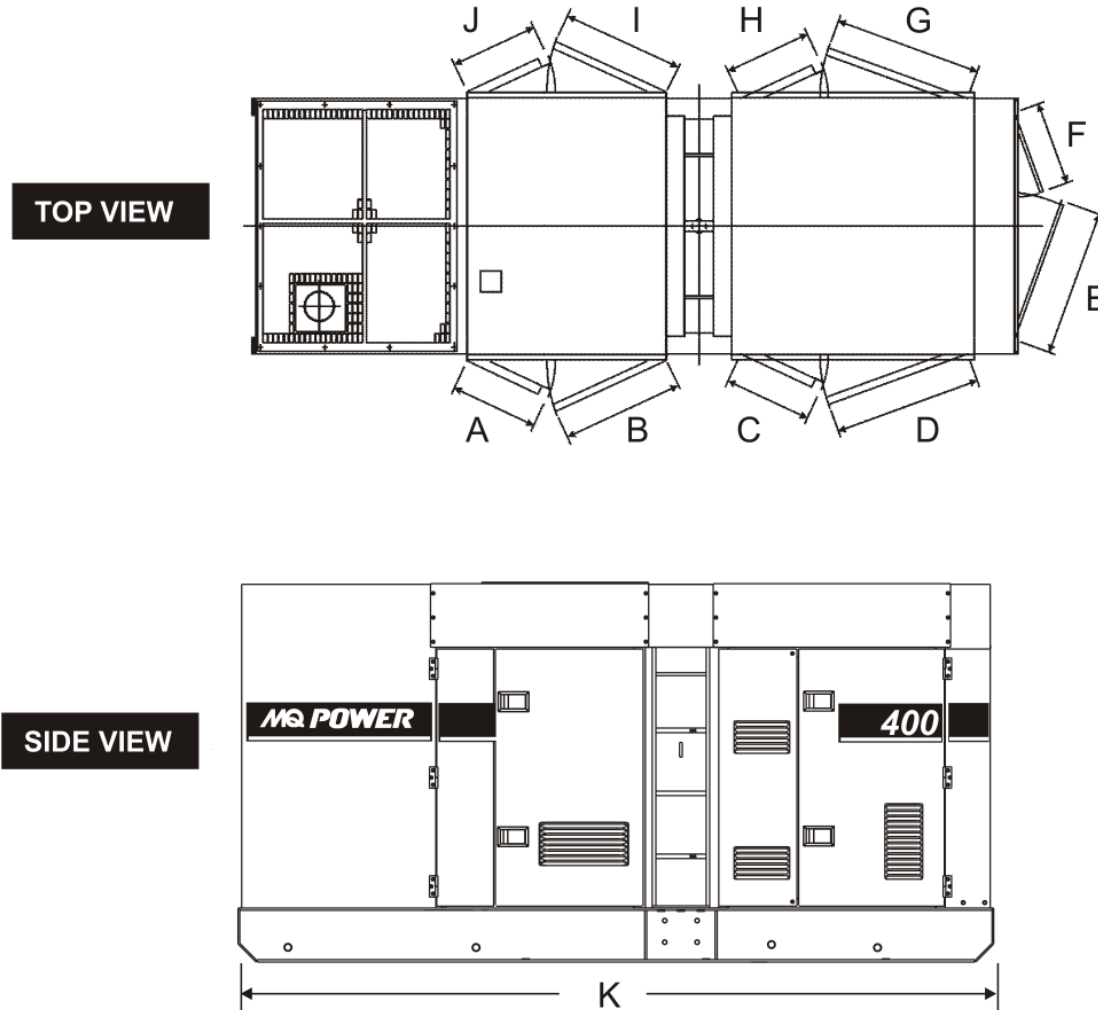

Figure 1. Dimensions

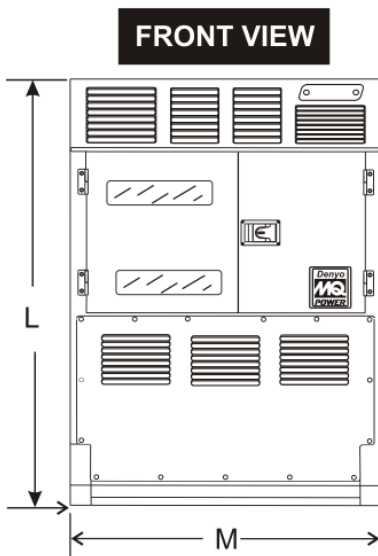
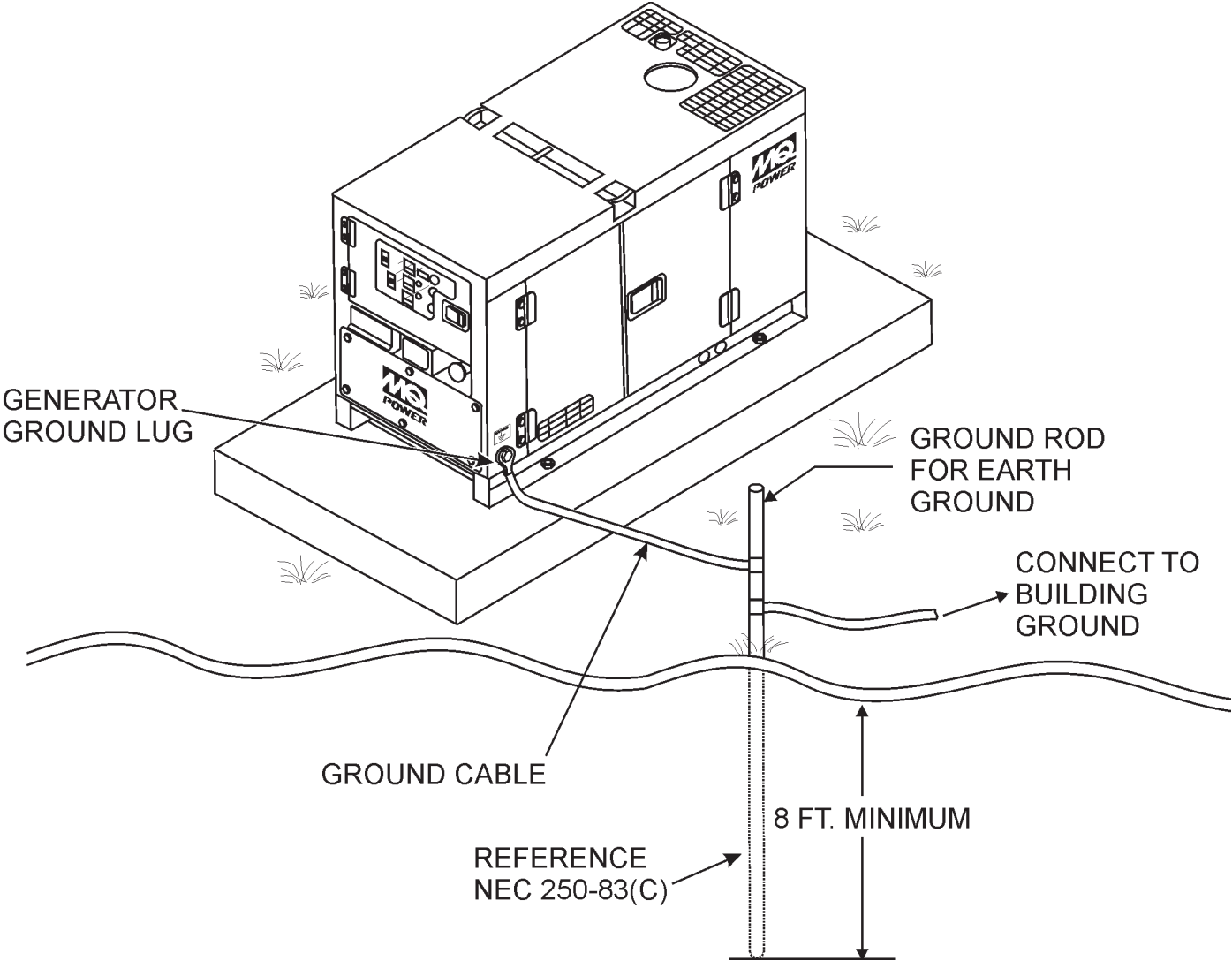

Table 3. Dimensions			
Reference Letter	Dimension in. (mm)	Reference Letter	Dimension in. (mm)
A	17.72 in. (450 mm)	H	23.23 in. (590 mm)
B	35.83 in. (910 mm)	I	35.83 in. (910 mm)
C	23.23 in. (590 mm.)	J	17.72 in. (450 mm)
D	31.89 in. (810 mm)	K	181.10 in. (4,600 mm)
E	18.11 in. (685 mm)	L	82.68 in. (2,100 mm)
F	22.24 in. (565 mm)	M	55.12 in. (1,400 mm)
G	31.89 in. (810 mm)		



**Figure 2. Typical Generator Grounding Application**

## OUTDOOR INSTALLATION

Install the generator in a area that is free of debris, bystanders, and overhead obstructions. Make sure the generator is on secure level ground so that it cannot slide or shift around. Also install the generator in a manner so that the exhaust will not be discharged in the direction of nearby homes.

The installation site must be relatively free from moisture and dust. All electrical equipment should be protected from excessive moisture. Failure to do will result in deterioration of the insulation and will result in short circuits and grounding.

Foreign materials such as dust, sand, lint and abrasive materials have a tendency to cause excessive wear to engine and alternator parts.

### CAUTION

Pay close attention to ventilation when operating the generator inside tunnels and caves. The engine exhaust contains noxious elements. Engine exhaust must be routed to a ventilated area.

## INDOOR INSTALLATION

Exhaust gases from diesel engines are extremely poisonous. Whenever an engine is installed indoors the exhaust fumes must be vented to the outside. The engine should be installed at least two feet from any outside wall. Using an exhaust pipe which is too long or too small can cause excessive back pressure which will cause the engine to heat excessively and possibly burn the valves.

## MOUNTING

The generator must be mounted on a solid foundation (such as concrete) and set firmly on the foundation to isolate vibration of the generator when it is running. The generator must set at least 6 inches above the floor or grade level (in accordance to NFPA 110, Chapter 5-4.1). **DO NOT** remove the metal skids on the bottom of the generator. They are to resist damage to the bottom of the generator and to maintain alignment.

## GENERATOR GROUNDING

To guard against electrical shock and possible damage to the equipment, it is important to provide a good **EARTH** ground.

Article 250 (Grounding) of the National Electrical Code (NEC) provides guide lines for proper grounding and specifies that the cable ground shall be connected to the grounding system of the building as close to the point of cable entry as practical.

NEC articles 250-64(b) and 250-66 set the following grounding requirements:

1. Use one of the following wire types to connect the generator to earth ground.
  - a. Copper - 10 AWG (5.3 mm<sup>2</sup>) or larger.
  - b. Aluminum - 8 AWG (8.4 mm<sup>2</sup>) or larger.
2. When grounding the generator (Figure 2) connect the ground cable between the lock washer and the nut on the generator and tighten the nut fully. Connect the other end of the ground cable to earth ground.
3. NEC article 250-52(c) specifies that the earth ground rod should be buried a minimum of 8 ft. into the ground.

### NOTICE

When connecting the generator to any buildings electrical system **ALWAYS** consult with a licensed electrician.

## GENERATOR

The MQ Power Model DCA400SSI is a 320 kW generator (Figure 3) that is designed as a high quality portable (requires a trailer for transport) power source for telecom sites, lighting facilities, power tools, submersible pumps and other industrial and construction machinery.

## ENGINE OPERATING PANEL

The “Engine Operating Panel” is provided with the following:

- Tachometer
- Emergency Stop Switch
- Water Temperature Gauge
- Oil Pressure Gauge
- Charging Ammeter Gauge
- Fuel Level Gauge
- Pre-Heat Lamp
- Engine Speed Switch
- Battery Switch
- Engine Alarm Lamps (5)

## GENERATOR CONTROL PANEL

The “Generator Control Panel” is provided with the following:

- Frequency Meter (Hz)
- AC Ammeter (Amps)
- AC Voltmeter (Volts)
- Ammeter Change-Over Switch
- Voltmeter Change-Over Switch
- Voltage Regulator
- Panel Light/Panel Light Switch
- 3-Pole, 1,000 amp Main Circuit Breaker
- “Control Box” (located behind the Gen. Control Panel)
  - Automatic Voltage Regulator
  - Current Transformer
  - Over-Current Relay
  - Voltage Rectifier
  - Starter Relay
  - Engine Controller (Computer Controlled)
  - Voltage Change-Over Board

## OUTPUT TERMINAL PANEL

The “Output Terminal Panel” is provided with the following:

- Three 120/240V output receptacles (CS-6369), 50A
- Three auxiliary circuit breakers, 50A
- Two 120V output receptacles (GFCI), 20A
- Two GFCI circuit breakers, 20A
- Eight output terminal lugs (3Ø power)
- Battery Charger (Optional)
- Water Heater (Optional)

## OPEN DELTA EXCITATION SYSTEM

The DCA400SSI generator is equipped with the state of the art “Open-Delta” excitation system. The open delta system consist of an electrically independent winding wound among stationary windings of the AC output section.

There are four connections of the open delta A, B, C and D. During steady state loads, the power from the voltage regulator is supplied from the parallel connections of A to B, A to D, and C to D. These three phases of the voltage input to the voltage regulator are then rectified and are the excitation current for the exciter section.

When a heavy load, such as a motor starting or a short circuit occurs, the automatic voltage regulator (AVR) switches the configuration of the open delta to the series connection of B to C. This has the effect of adding the voltages of each phase to provide higher excitation to the exciter section and thus better voltage response during the application of heavy loads.

The connections of the AVR to the AC output windings are for sensing only. No power is required from these windings. The open-delta design provides virtually unlimited excitation current, offering maximum motor starting capabilities. The excitation does not have a “fixed ceiling” and responds according the demands of the required load.

## ENGINE

The DCA400SSI is powered by a 6 cylinder, water cooled, direct injection, turbocharged air-to-air ISUZU 6WG1X Diesel Engine. This engine is designed to meet every performance requirement for the generator. Reference Table 2 for engine specifications.

In keeping with MQ Power’s policy of constantly improving its products, the specifications quoted herein are subject to change without prior notice.

## ELECTRIC GOVERNOR SYSTEM

The electric governor system controls the RPMs of the engine. When the engine demand increases or decreases, the governor system regulates the frequency variation to  $\pm 0.25\%$ .

## EXTENSION CABLES

When electric power is to be provided to various tools or loads at some distance from the generator, extension cords are normally used. Cables should be sized to allow for distance in length and amperage so that the voltage drop between the generator and point of use (load) is held to a minimum. Use the cable selection chart (Table 6) as a guide for selecting proper extension cable size.



# MAJOR COMPONENTS

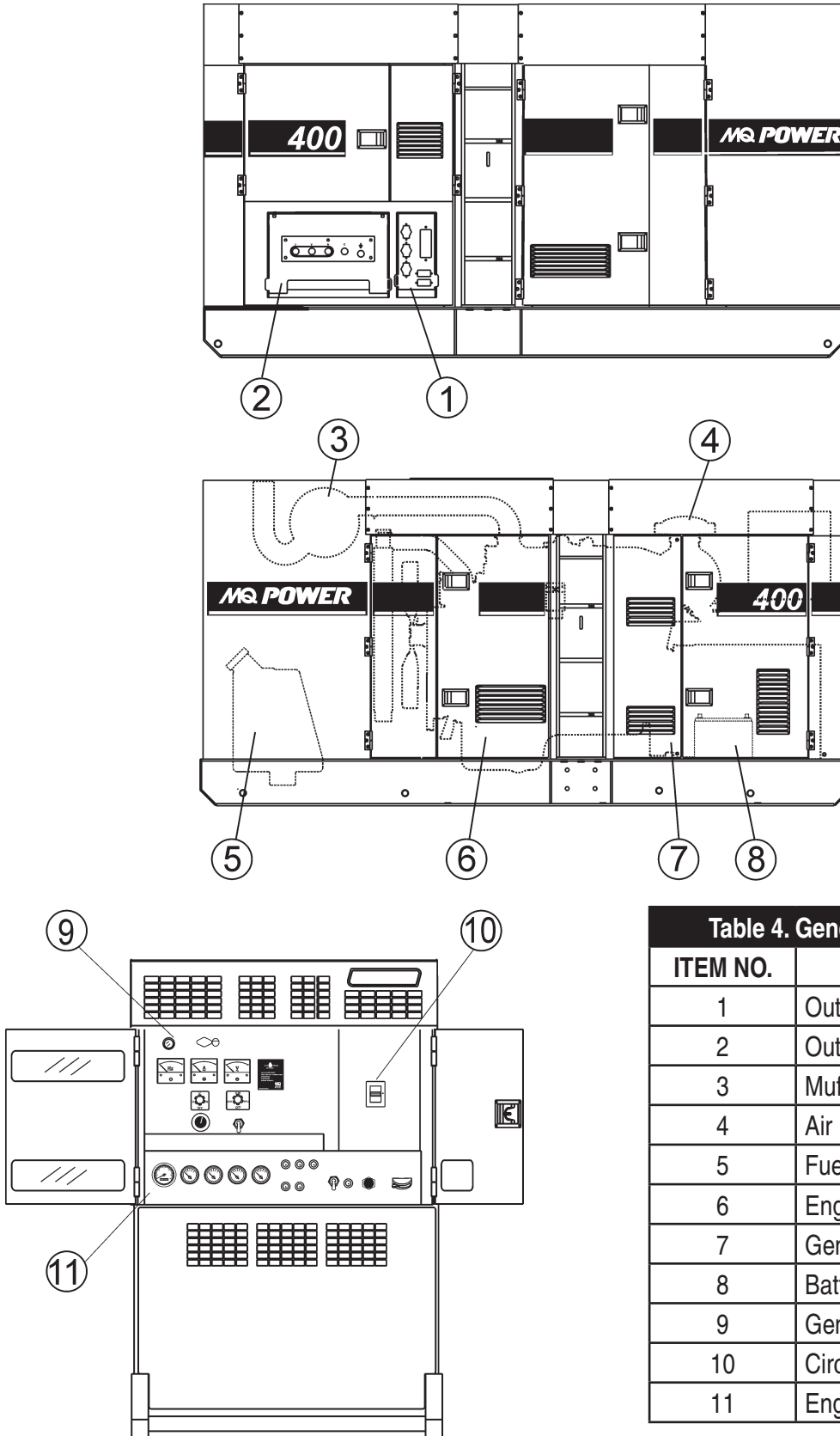

Table 4. Generator Major Components	
ITEM NO.	DESCRIPTION
1	Output Receptacles Assembly
2	Output Terminal Panel Assembly
3	Muffler Assembly
4	Air Filter Assembly
5	Fuel Tank Assembly
6	Engine and Radiator Assembly
7	Generator Assembly
8	Battery Assembly
9	Generator Control Panel Assembly
10	Circuit Breaker Assembly
11	Engine Operating Panel Assembly

Figure 3. Major Components

# GENERATOR CONTROL PANEL

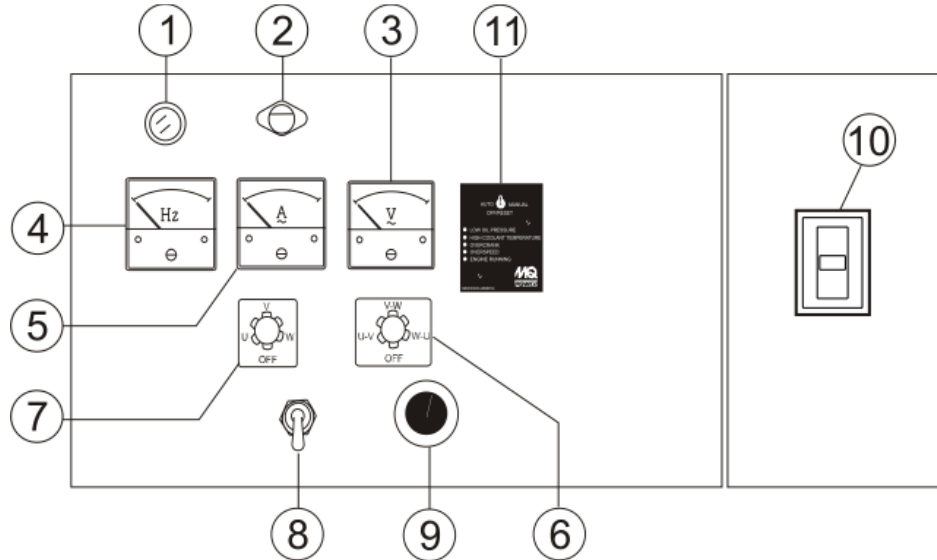

Figure 4. Generator Control Panel

The definitions below describe the controls and functions of the DCA400SSI Generator Control Panel (Figure 4).

1. **Pilot Lamp** — Indicates the system is running.
2. **Panel Light** — Normally used in dark areas or at night time. When activated, panel lights will illuminate. When the generator is not in use be sure to turn the panel light switch to the **OFF** position.
3. **AC Voltmeter** — Indicates the output voltage present at the **U,V, and W Output Terminal Lugs**.
4. **Frequency Meter** — Indicates the output frequency in hertz (Hz). Normally 60 Hz.
5. **AC Ammeter** — Indicates the amount of current the load is drawing from the generator per leg selected by the ammeter phase-selector switch.
6. **Voltmeter Change-Over Switch** — This switch allows the AC voltmeter to indicate phase to phase voltage between any two phases of the output terminals or to be switched off.
7. **Ammeter Change-Over Switch** — This switch allows the AC ammeter to indicate the current flowing to the load connected to any phase of the output terminals, or to be switched off. This switch does not effect the generator output in any fashion, it is for current reading only.

8. **Panel Light Switch** — When activated will turn on control panel light.
9. **Voltage Regulator Control** — Allows  $\pm 15\%$  manual adjustment of the generator's output voltage.
10. **Main Circuit Breaker** — This three-pole, 1,000 amp main breaker is provided to protect the **U,V, and W Output Terminal Lugs** from overload.
11. **Auto On/Off Engine Controller (MPEC)** —

This controller has a vertical row of status LED's (inset), that when lit, indicate that an engine malfunction (fault) has been detected. When a fault has been detected the engine controller will evaluate the fault and all major faults will shutdown the generator. During **cranking cycle**, The MPEC will attempt to crank the engine for 10 seconds before disengaging.

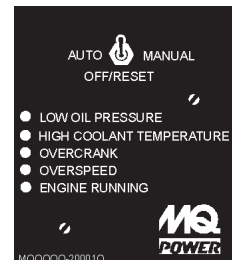

If the engine does not engage (start) by the third attempt, the engine will be shutdown by the engine controller's **Over Crank Protection** mode. If the engine engages at a speed (RPM's) that is not safe, the controller will shutdown the engine by initializing the **Over Speed Protection** mode.

# GENERATOR CONTROL PANEL

Also the engine controller will shut down the engine in the event of low oil pressure, high coolant temperature, low coolant level, and loss of magnetic pickup. These conditions can be observed by monitoring the LED status indicators on the front of the controller module.

■ **MPEC Control Switch** — This switch controls the running of the unit. If this switch is set to the **OFF/RESET** position, the unit will not run. When this switch is set to the manual position, the generator will start immediately.

If the generator is to be connected to a building's AC power source via a transfer switch (isolation), place the switch in the AUTO position. In this position, should an outage occur, the automatic transfer switch (ATS) will start the generator automatically via the generator's auto-start contacts connected to the ATS's start contacts. Please refer to your ATS installation manual for further instructions for the correct installation of the auto-start contacts of the generator to the ATS.

■ **Low Oil Pressure** — Indicates the engine pressure has fallen below a safe operating level. The oil pressure is detected using variable resistive values from the oil pressure sending unit. This is considered a **major** fault.

■ **High Coolant Temperature** — Indicates the engine temperature has exceeded a safe operating level. The engine temperature is detected using variable resistive values from the temperature sending unit. This is considered a **major** fault.

■ **Overcrank Shutdown** — Indicates the unit has attempted to start a pre-programmed number of times and has failed to start. The number of cycles and duration are programmable. It is pre-set at 3 cycles with a 10-second duration. This is considered a **major** fault.

■ **Overspeed Shutdown** — Indicates the engine is running at an unsafe speed. This is considered a **major** fault.

■ **Engine Running** — Indicates that engine is running at a safe operating speed.

Located behind the generator control panel is the **Generator Control Box**. This box contains some of the necessary electronic components required to make the generator function.

The **Control Box** is equipped with the following major components:

- Over-Current Relay
- Voltage Rectifier (AVR)
- Starter Relay
- Current Transformer
- Voltage Change-Over Board
- Three Phase Circuit Breaker

## NOTICE

Remember the **overcurrent relay** monitors the current flowing from the **U, V, and W Output Terminal Lugs** to the load.

In the event of a short circuit or over current condition, it will automatically trip the 1000 amp main breaker.

To restore power to the **Output Terminal Panel**, press the reset button on the overcurrent relay and place the **main** circuit breaker in the **closed** position (**ON**).

# ENGINE OPERATING PANEL

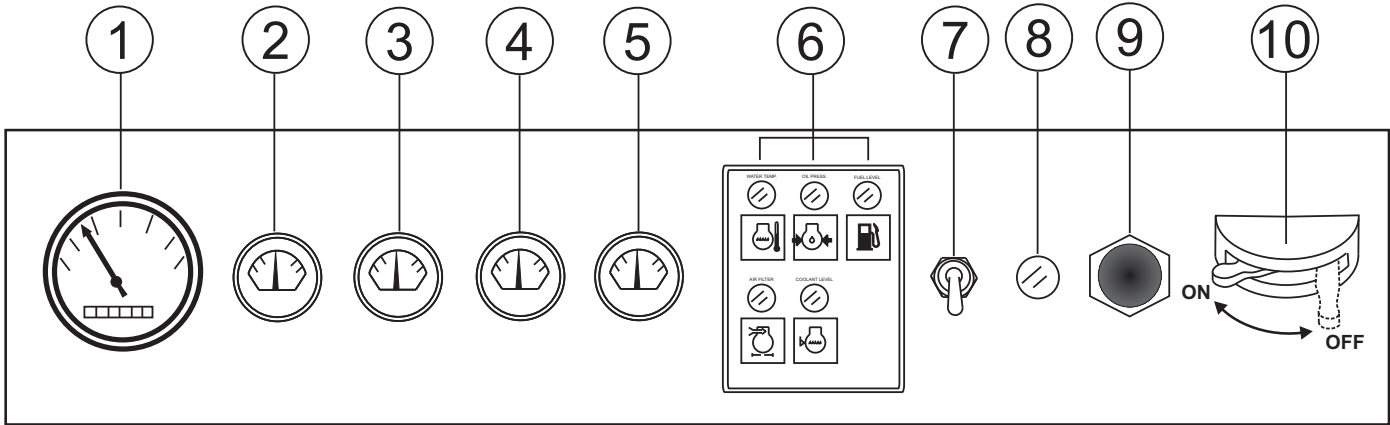

**Figure 5. Engine Operating Panel**

The definitions below describe the controls and functions of the DCA400SSI Engine Operating Panel (Figure 5).

1. **Tachometer** — Indicates engine speed in RPM's for 60 Hz operation. This meter should indicate 1800 RPM's when the rated load is applied. In addition a built in hour meter will record the number of operational hours that the generator has been in use.
2. **Oil Pressure Gauge** — During normal operation this gauge be should read between 28 to 85 psi. (193~586 kPa). When starting the generator the oil pressure may read a little higher, but after the engine warms up the oil pressure should return to the correct pressure range.
3. **Water Temperature Gauge** — During normal operation this gauge be should read between 167° and 203°F (75°~95°C).
4. **Charging Ammeter Gauge** — Indicates the current being supplied by the engine's alternator which provides current for generator's control circuits and battery charging system.
5. **Fuel Gauge** — Indicates amount of diesel fuel available.
6. **Engine Warning Lamps** — There are three engine warning lamps, they are defined as follows:

- a. **Overheat Lamp** — This lamp goes **ON** when the cooling water temperature rises abnormally. If the lamp goes **ON** during normal operation of the generator, the emergency shutdown device will stop the engine automatically.



- b. **Low Oil Pressure Lamp** — During normal operation of the generator this lamp should remain **OFF**. When the **Auto-OFF/Reset-Manual** switch is set



to the **MANUAL** position to start the engine, the lamp will be lit. When the oil pressure rises after start-up the lamp will go **OFF**. If this lamp is ever lit (**ON**) during normal operation of the generator, the emergency shutdown device will stop the engine automatically.

- c. **Low Fuel Level Lamp** — When this lamp is **ON**, it is time to stop the engine and add fuel. Remember to let the engine cool before adding fuel.



- d. **Air Filter Alarm** — When the air filter element is clogged, this lamp goes **ON** indicating the element should be immediately cleaned or replaced.



- e. **Coolant Level Alarm** — This lamp goes **ON** when the coolant level is low. If this lamp goes **ON** while the engine is in operation, the emergency shutdown device will automatically stop the engine.

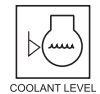

7. **Engine Speed Switch** — This switch controls the speed of the engine (low/high).
8. **Pre-Heat Lamp** — When ECU is placed in **AUX** position, pre-heat lamp will be **ON**. When pre-heat cycle is completed, lamp will turn **OFF**.
9. **Emergency Stop Button** — Push this button inward to stop the engine in the event of an emergency. **DO NOT** use this button as a means of stopping the engine.
10. **Battery Switch** — This switch should be set to the **ON** position during normal operation. When the engine has been stop, place this switch in the **OFF** position. **DO NOT** turn this switch during normal operation, it could cause damage to the electrical equipment.



# OUTPUT TERMINAL PANEL FAMILIARIZATION

## OUTPUT TERMINAL PANEL

The Output Terminal Panel (Figure 6) shown below is located on the right-hand side (left from control panel) of the generator. Lift up on the cover to gain access to receptacles and terminal lugs.

### NOTICE

Terminal legs "O" and "Ground" are considered bonded grounds.

## OUTPUT TERMINAL FAMILIARIZATION

The "Output Terminal Panel" (Figure 6) is provided with the following:

- Three (3) 120/240V output receptacles @ 50 amp
- Three (3) Circuit Breakers @ 50 amps
- Two (2) 120V GFCI receptacles @ 20 amp
- Two (2) GFCI Circuit Breakers @ 20 amps
- Eight (8) Output Terminal Lugs ( U, V, W, O, Ground)

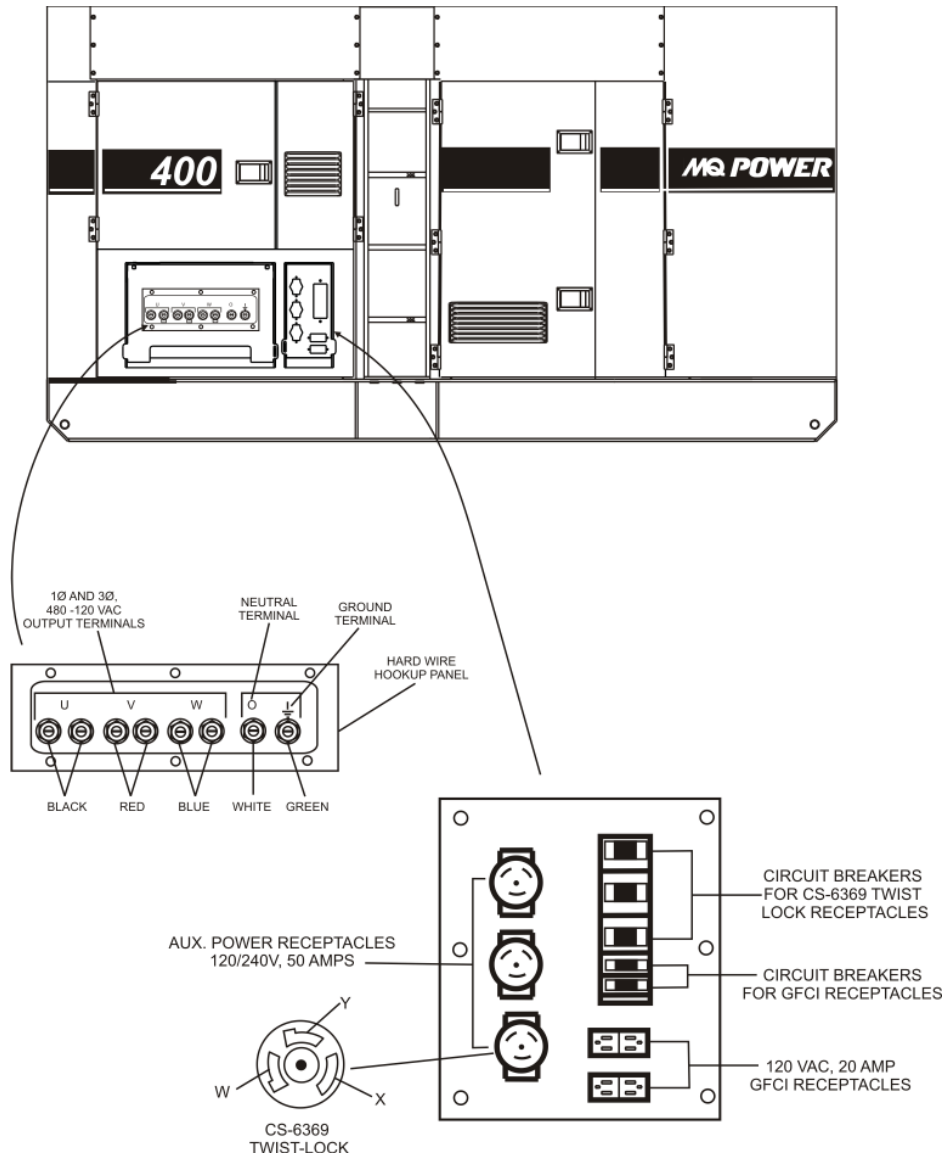

Figure 6. Output Terminal Panel

# OUTPUT TERMINAL PANEL FAMILIARIZATION

## 120 VAC GFCI Receptacles

There are two 120 VAC, 20 amp GFCI (Duplex Nema 5-20R) receptacles provided on the output terminal panel. These receptacles can be accessed in **any voltage selector switch** position. Each receptacle is protected by a 20 amp circuit breaker. These breakers are located directly above the GFCI receptacles. Remember the load output (current) of both GFCI receptacles is dependent on the load requirements of the U, V, and W output terminal lugs.

Pressing the **reset** button resets the GFCI receptacle after being tripped. Pressing the **test button** (See Figure 7) in the center of the receptacle will check the GFCI function. Both receptacles should be tested at least once a month.

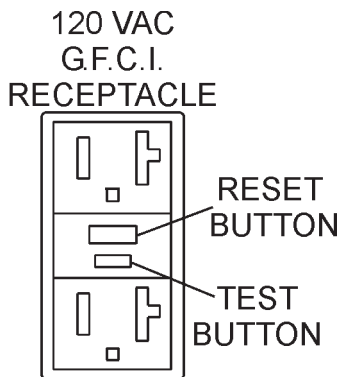

Figure 7. G.F.C.I. Receptacle

## Twist Lock Dual Voltage 120/240 VAC Receptacles

There are three 120/240V, 50 amp auxiliary twist-lock (CS-6369) receptacles (Figure 8) provided on the output terminal panel. These receptacles can **only** be accessed when the voltage selector switch is placed in the **single-phase 240/120 position**.

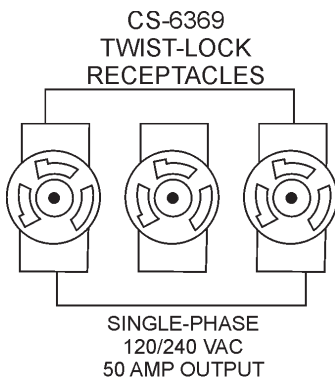

Figure 8. 120/240V Twist-Lock Auxiliary Receptacles

Each auxiliary receptacle is protected by a 50 amp circuit breaker. These breakers are located directly above the GFCI receptacles. Remember the load output (current) on all three receptacles is dependent on the load requirements of the **Output Terminal Lugs**.

Turn the **voltage regulator control knob** (Figure 9) on the control panel to obtain the desired voltage. Turning the knob clockwise will **increase** the voltage, turning the knob counter-clockwise will **decrease** the voltage.



Figure 9. Voltage Regulator Control Knob

# OUTPUT TERMINAL PANEL FAMILIARIZATION

## Connecting Loads

Loads can be connected to the generator by the **Output Terminal Lugs** or the convenience receptacles (Figure 10). Make sure to read the operation manual before attempting to connect a load to the generator.

To protect the output terminals from overload, a 3-pole, 1000A **main** circuit breaker is provided. Make sure to switch **ALL** circuit breakers to the **OFF** position prior to starting the engine.

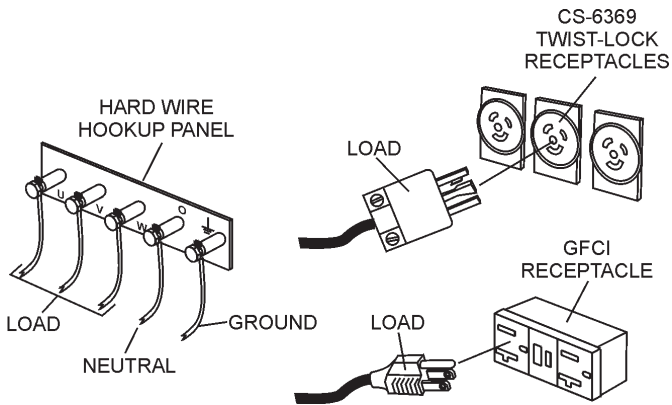

Figure 10. Connecting Loads

## Over Current Relay

An **over current relay** (Figure 11) is connected to the main circuit breaker. In the event of an overload, both the circuit breaker and the over current relay may trip. If the circuit breaker can not be reset, the **reset button** on the over current relay must be pressed. The over current relay is located in the control box.

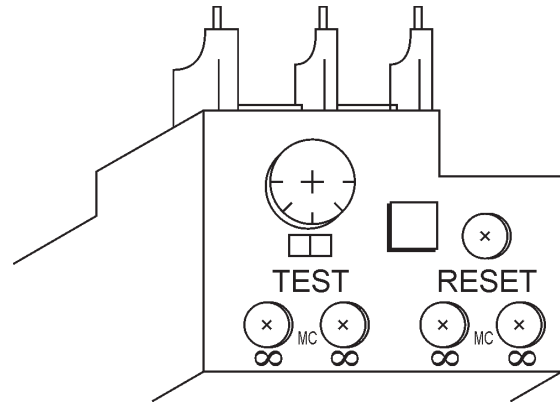

Figure 11. Over Current Relay



# LOAD APPLICATION

## SINGLE PHASE LOAD

Always be sure to check the nameplate on the generator and equipment to insure the wattage, amperage, frequency, and voltage requirements are satisfactorily supplied by the generator for operating the equipment.

Generally, the wattage listed on the nameplate of the equipment is its rated output. Equipment may require 130—150% more wattage than the rating on the nameplate, as the wattage is influenced by the efficiency, power factor and starting system of the equipment.

### NOTICE

If wattage is not given on the equipment's name plate, approximate wattage may be determined by multiplying nameplate voltage by the nameplate amperage.

$$\text{WATTS} = \text{VOLTAGE} \times \text{AMPERAGE}$$

The power factor of this generator is 0.8. See Table 5 below when connecting loads.

**Table 5. Power Factor By Load**

Type of Load	Power Factor
Single-phase induction motors	0.4-0.75
Electric heaters, incandescent lamps	1.0
Fluorescent lamps, mercury lamps	0.4-0.9
Electronic devices, communication equipment	1.0
Common power tools	0.8

**Table 6. Cable Selection (60 Hz, Single Phase Operation)**

Current in Amperes	Load in Watts		Maximum Allowable Cable Length			
	At 100 Volts	At 200 Volts	#10 Wire	#12 Wire	#14 Wire	#16 Wire
2.5	300	600	1000 ft.	600 ft.	375 ft.	250 ft.
5	600	1200	500 ft.	300 ft.	200 ft.	125 ft.
7.5	900	1800	350 ft.	200 ft.	125 ft.	100 ft.
10	1200	2400	250 ft.	150 ft.	100 ft.	
15	1800	3600	150 ft.	100 ft.	65 ft.	
20	2400	4800	125 ft.	75 ft.	50 ft.	

CAUTION: Equipment damage can result from low voltage

## THREE PHASE LOAD

When calculating the power requirements for 3-phase power use the following equation:

$$\text{KVA} = \frac{\text{VOLTAGE} \times \text{AMPERAGE} \times 1.732}{1000}$$

### NOTICE

If 3Ø load (kVA) is not given on the equipment nameplate, approximate 3Ø load may be determined by multiplying voltage by amperage by 1.732.

### NOTICE

Motors and motor-driven equipment draw much greater current for starting than during operation.

An inadequate size connecting cable which cannot carry the required load can cause a voltage drop which can burn out the appliance or tool and overheat the cable. See Table 6.

- When connecting a resistance load such as an incandescent lamp or electric heater, a capacity of up to the generating set's rated output (kW) can be used.
- When connecting a fluorescent or mercury lamp, a capacity of up to the generating set's rated output (kW) multiplied by 0.6 can be used.
- When connecting an electric drill or other power tools, pay close attention to the required starting current capacity.

When connecting ordinary power tools, a capacity of up to the generating set's rated output (kW) multiplied by 0.8 can be used.

### DANGER

Before connecting this generator to any building's electrical system, a **licensed electrician** must install an **isolation (transfer) switch**. Serious damage to the building's electrical system may occur without this transfer switch.

# GENERATOR OUTPUTS

## GENERATOR OUTPUT VOLTAGES

A wide range of voltages are available to supply voltage for many different applications. Voltages are selected by applying jumpers (6) to the **voltage change-over board** (Figure 12). To obtain some of the voltages as listed in Table 7 (see below) will require a fine adjustment using the **voltage regulator (VR) control knob** located on the control panel.

### Voltage Change-Over Board

The **voltage change-over board** (Figure 12) is located on the control box, behind the generator control panel. This board has been provided for ease of voltage selection.

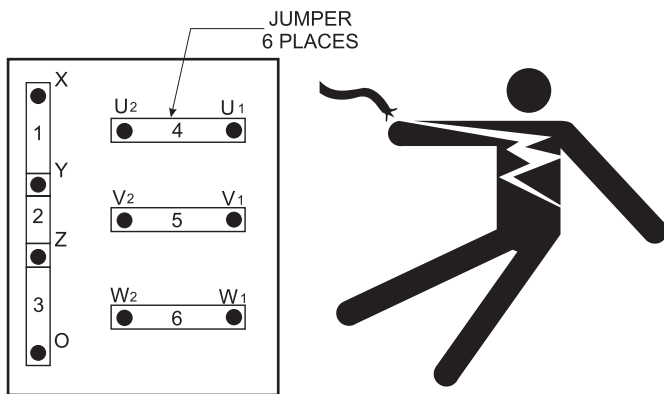

Figure 12. Voltage Change-Over Board

### CAUTION

**NEVER** attempt to place jumper plates on the **voltage change-over board** while the generator is in operation. There exist the possibility of **electrocution, electrical shock or burn, which can cause severe bodily harm or even death!**

Table 7. Voltages Available

	208V	220V	240V	416V	440V	480V
Three Phase (Switchable)						
Single Phase (Switchable)	120V	127V	139V	240V	254V	277V

## Generator Amperage

Tables 8 and 9 describe the generator's current output capability for both 1Ø-phase and 3Ø phase applications.

Table 8. Generator Ampere Ratings — 1Ø

kW	120V	139V	240V	277V	480V
80	222	191	111	96	55
110	305	263	152	131	76
140	388	335	194	167	97
170	472	407	236	203	118
200	555	480	277	240	138
230	638	551	319	275	160
260	722	623	361	311	180
290	805	695	402	347	201
320 (Max)	889	767	444	383	222

These calculations reflect the maximum amount of current the generator can provide at each output terminal pair. To obtain the total generator amperage, multiply by 3.

Example 1: 488.6 amps @ 120V per output terminal pair X 3 = 1,486 amps  
 Example 2: 244.3 amps @ 240V per out put terminal pair X 3 = 733 amps

Table 9. Generator Ampere Ratings — 3Ø

KVA	240V	480V
100	240	120
130	312	156
160	384	192
190	457	228
220	529	264
250	601	300
280	674	337
310	746	373
340	818	409
370	890	445
400	962	481

# GENERATOR OUTPUTS/GAUGE READING

## Maximum Amps

Table 10 shows the **maximum** amps the generator can provide. **DO NOT** exceed the maximum amps as listed.

Table 10. Generator Maximum Amps	
Model	DCA400SSI
Rated Voltage	Maximum Amps
Single Phase 120 Volt	888.9 amps (4 wire)
Single Phase 240 Volt	444.4 amps (4 wire)
Three Phase 240 Volt	962.3 amps
Three Phase 480 Volt	481.1 amps

## HOW TO READ THE OUTPUT TERMINAL GAUGE

The AC ammeter and AC voltmeter change-over switches on the control panel **DO NOT** effect the generator output. They are provided to help observe how much power is being supplied, produced at the UVWO terminals lugs.

When the voltage change-over board is jumpered for 3 $\phi$ , 240V operation (See Figures 14 and 15), place the **AC Voltmeter Change-Over Switch** (See Figures 16 and 17) to the W-U position and the **AC Ammeter Change-Over Switch** (Figure 16) to the U or W position to read the output on the selected leg.

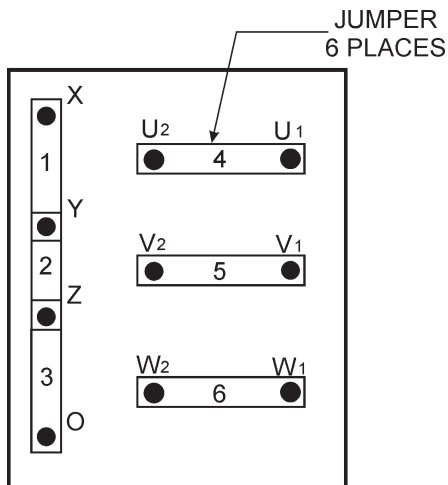

Figure 13. Voltage Change-Over Board 240V Configuration

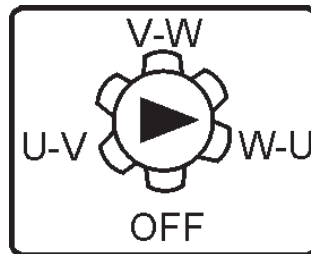

Figure 14. AC Voltmeter Change-Over Switch

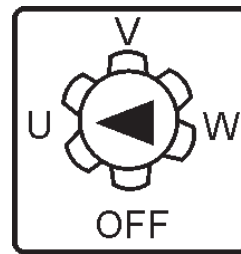

Figure 16. AC Ammeter Change-Over Switch

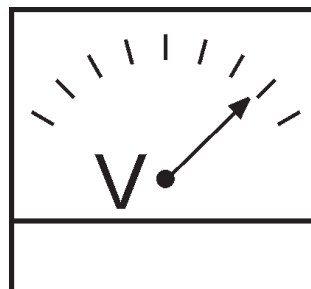

Figure 15. AC Voltmeter Gauge (Volt reading on W-U Lug)

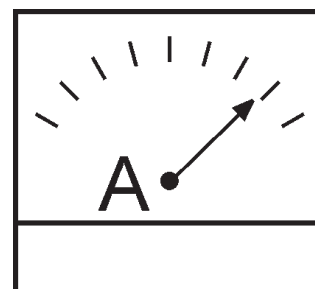

Figure 17. AC Ammeter Gauge (Amp reading on U lug)

### NOTICE

The **ammeter** gauge will only show a reading when the **Output Terminal Lugs** are connected to a load and in use.

# OUTPUT TERMINAL PANEL CONNECTIONS

## UVWO TERMINAL OUTPUT VOLTAGES

Various output voltages can be obtained using the UVWO output terminal lugs. The voltages at the terminals are dependent on the placement of the jumpers plates (6) on the **Voltage Change-Over Board** and the adjustment of the **Voltage Regulator Control Knob**.

Remember the voltage change-over board determines the **range** of the output voltage and can be configured in two different positions that provide 6 different output voltages at the UVWO output terminals. The generator is shipped from the factory in the 240V configuration. The voltage regulator (VR) allows the user to increase or decrease the selected voltage.

### 3Ø-240V UVWO Terminal Output Voltages

1. Jumper the voltage change-over board for 240V operation as shown in Figure 18.

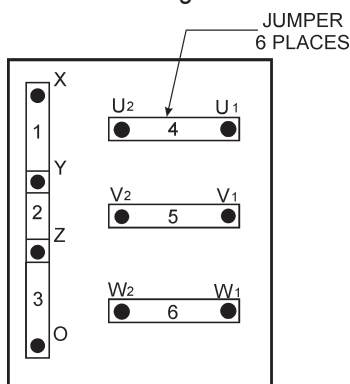

**Figure 18. Voltage Change-Over Board 240V Configuration**

2. Connect the load wires to the UVWO terminals as shown in Figure 19.

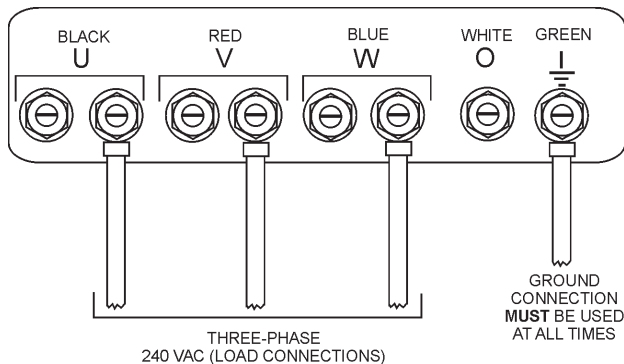

**Figure 19. UVWO Terminal Lugs**

3. Turn the voltage regulator knob (Figure 20) clockwise to increase voltage output, turn counterclockwise to decrease voltage output. Use voltage regulator adjustment knob whenever fine tuning of the output voltage is required



**Figure 20. Voltage Regulator Knob**

### 1Ø-240V UVWO Terminal Output Voltages

1. Make sure the voltage change-over board is jumpered for 240V operation as shown in Figure 18.
2. Connect the load wires to the UVWO terminals as shown in Figure 21.

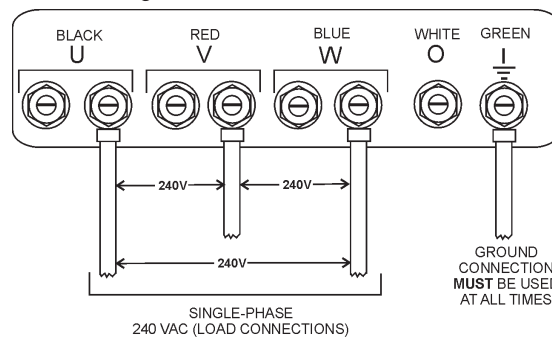

**Figure 21. UVWO Terminal Lugs 1Ø-240V Connections**

### 1Ø-120V UVWO Terminal Output Voltages

1. Make sure the voltage change-over board is jumpered for 240V operation as shown in Figure 18.
2. Adjust voltage regulator knob (Figure 20) for an output of 208V to obtain 120V at the UVWO terminals.
3. Connect the load wires to the UVWO terminals as shown in Figure 22.

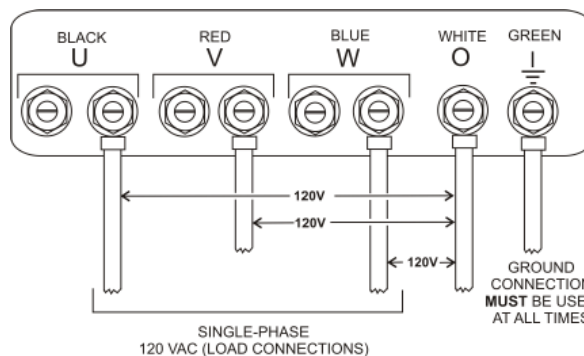
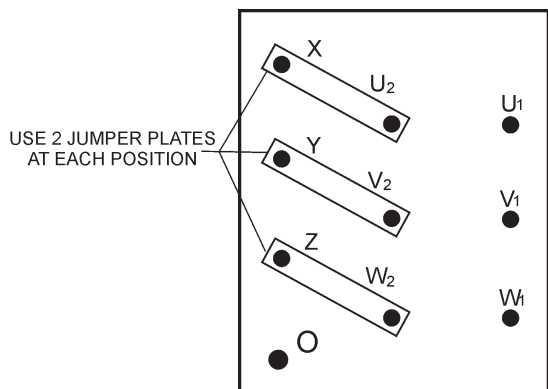

**Figure 22. UVWO Terminal Lugs 1Ø-120V Connections**

# OUTPUT TERMINAL PANEL CONNECTIONS

## 3Ø-480V UVW Terminal Output Voltages

1. Jumper the voltage change-over board for 480V operation as shown in Figure 23. This configuration uses 6 jumper plates in 3 different positions. Remember there are 2 jumper plates at every position. Every jumper plate **must** be used.



**Figure 23. Voltage Change-Over Board 480V Configuration**

2. Connect the load wires to the UVW terminals as shown in Figure 24.

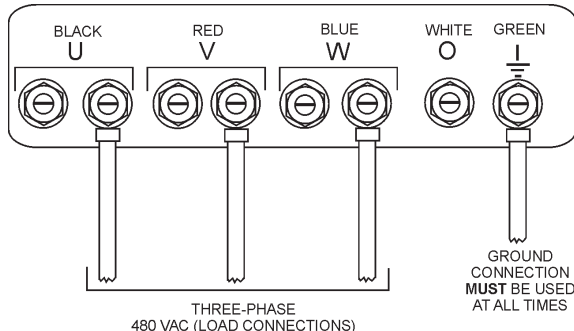

**Figure 24. UVW Terminal Lugs 3Ø-480V Connections**

### NOTICE

**ALWAYS** make sure that the connections to the UVW terminals are **secure** and **tight**. The possibility of arcing exists, that could cause a fire.

## 1Ø-480V UVW Terminal Output Voltages

1. Make sure the voltage change-over board is jumpered for 480V operation as shown in Figure 23.
2. Connect the load wires to the UVW terminals as shown in Figure 25.

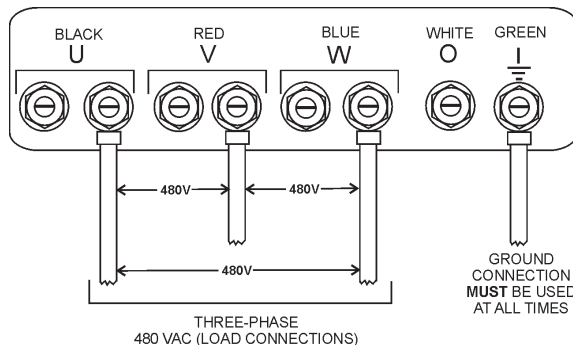

**Figure 25. UVW Terminal Lugs 1Ø-480V Connections**

## 1Ø-277V UVW Terminal Output Voltages

1. Make sure the voltage change-over board is jumpered for 480V operation as shown in Figure 23.
2. Connect the load wires to the UVW terminals as shown in Figure 26.

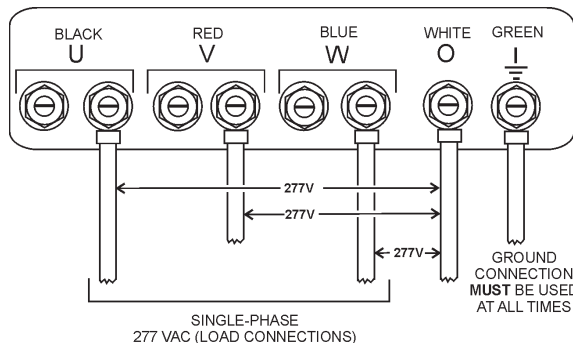

**Figure 26. UVW Terminal Lugs 1Ø-277V Connections**

## CIRCUIT BREAKERS

To protect the generator from an overload, a 3-pole, 600 amp, main circuit breaker is provided to protect the **U, V, and W Output Terminals** from overload. In addition two single-pole, 20 amp **GFCI** circuit breakers are provided to protect the GFCI receptacles from overload. Three 50 amp **load** circuit breakers have also been provided to protect the auxiliary receptacles from overload. Make sure to switch **ALL** circuit breakers to the **OFF** position prior to starting the engine.

## LUBRICATION OIL

Fill the engine crankcase with lubricating oil through the filler hole, but **DO NOT** overfill. Make sure the generator is level and verify that the oil level is maintained between the two notches (Figure 27) on the dipstick. See Table 11 for proper selection of engine oil.

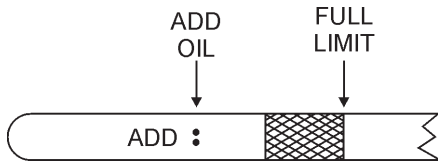

**Figure 27. Engine Oil Dipstick**

When checking the engine oil, be sure to check if the oil is clean. If the oil is not clean, drain the oil by removing the oil drain plug, and refill with the specified amount of oil as outlined in the **ISUZU Engine Owner's Manual**. Oil should be warm before draining.

Other types of motor oils may be substituted if they meet the following requirements:

- API Service Classification CC/SC
- API Service Classification CC/SD
- API Service Classification CC/SE
- API Service Classification CC/SF

Table 11. Recommended Motor Oil		OIL: SAE	
°F	°C		
122	50		
104	40	10W/40	30
86	30		
68	20		
50	10		
32	0	5W/30	10W/40
-14	-10		
-4	-20	ARCTIC OIL	15W/30
-22	-30		
-40	-40		
			10W/30
			10W
			20W/40

## FUEL CHECK

### **!** DANGER



Fuel spillage on a **hot** engine can cause a **fire** or **explosion**. If fuel spillage occurs, wipe up the spilled fuel completely to prevent fire hazards. **NEVER** smoke around or near the generator.

## Refilling the Fuel System

### **!** CAUTION

**ONLY** properly trained personnel who have read and understand this section should refill the fuel tank system.

This generator has an internal fuel tank located inside the trailer frame and may also be equipped with an environmental fuel tank (Figure 28). **ALWAYS** fill the fuel tanks with clean fresh **#2 diesel fuel**. **DO NOT** fill the fuel tanks beyond their capacities.

Pay attention to the fuel tank capacity when replenishing fuel. The fuel tank cap must be closed tightly after filling. Handle fuel in a safety container. If the container does not have a spout, use a funnel. Wipe up any spilled fuel immediately.

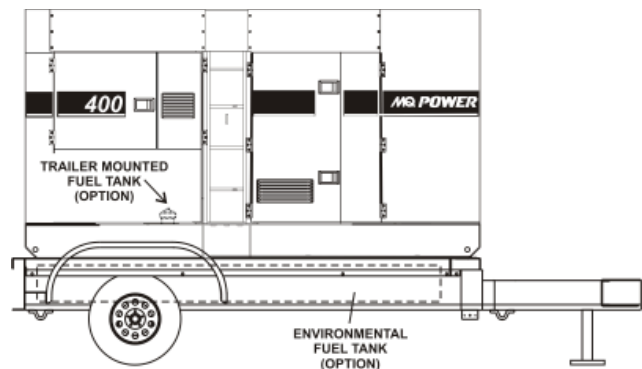

**Figure 28. Internal Fuel Tank System**

## Refueling Procedure:

### WARNING



**Diesel fuel** and its vapors are dangerous to your health and the surrounding environment. Avoid skin contact and/or inhaling fumes.

1. **Level Tanks** — Make sure fuel cells are level with the ground. Failure to do so will cause fuel to spill from the tank before reaching full capacity (Figure 29).

### CAUTION

**ALWAYS** place trailer on firm level ground before refueling to prevent spilling and maximize the amount of fuel that can be pumped into the tank.

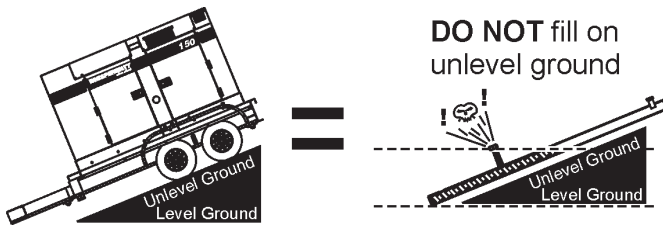

Figure 29. Only Fill on Level Ground

### NOTICE

**ONLY** use #2 diesel fuel when refueling.

2. Open cabinet doors on the “right side” of the generator (from generator control panel position). Remove fuel cap and fill tank (Figure 30).

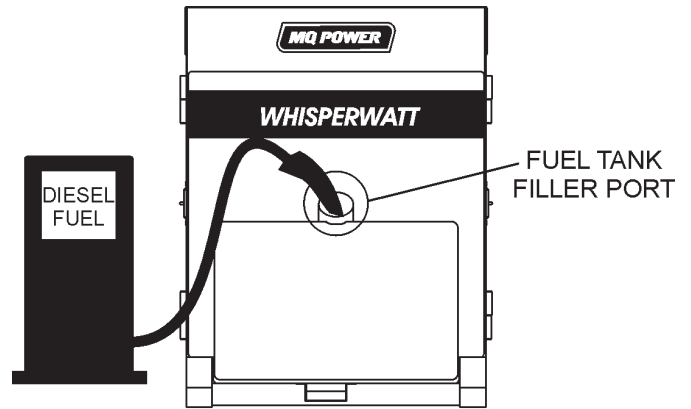

Figure 30. Fueling the Generator

3. **NEVER overfill fuel tank** — It is important to read the fuel gauge when filling trailer fuel tank. **DO NOT** wait for fuel to rise in filler neck (Figure 31).

FUEL GAUGE LOCATED ON CONTROL PANEL

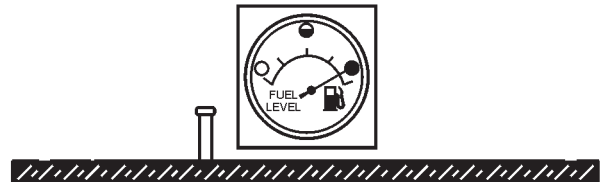

Figure 31. Full Fuel Tank

### CAUTION

**DO NOT OVERFILL** fuel system. Leave room for fuel expansion. Fuel expands when heated (Figure 32).



Figure 32. Fuel Expansion

## COOLANT (ANTIFREEZE/SUMMER COOLANT/WATER)

ISUZU recommends ISUZU antifreeze/summer coolant for use in their engines, which can be purchased in concentrate (and mixed with 50% demineralized water) or pre-diluted. See the **ISUZU Engine Owner's Manual** for further details.

**WARNING**



If adding coolant/antifreeze mix to the radiator, **DO NOT** remove the radiator cap until the unit has completely cooled. The possibility of **hot!** coolant exists which can cause severe burns.

Day-to-day addition of coolant is done from the recovery tank. When adding coolant to the radiator, **DO NOT** remove the radiator cap until the unit has completely cooled. See Table 12 for engine, radiator, and recovery tank coolant capacities. Make sure the coolant level in the recovery tank is always between the “H” and the “L” markings.

Engine and Radiator	15.8 Gal (60 liters)
Reserve Tank	TBD

## Operation in Freezing Weather

When operating in freezing weather, be certain the proper amount of antifreeze (Table 13) has been added.

Vol % Anti-Freeze	Freezing Point	
	°C	°F
50	-37	-34

**NOTICE**

When the antifreeze is mixed with water, the antifreeze mixing ratio **must be** less than 50%.

## Cleaning the Radiator

The engine may overheat if the radiator fins become overloaded with dust or debris. Periodically clean the radiator fins with compressed air. Cleaning inside the machine is dangerous, so clean only with the engine turned off and the **negative** battery terminal disconnected.

## AIR CLEANER

Periodic cleaning/replacement is necessary. Inspect it in accordance with the **ISUZU Engine Owner's Manual**.

## FAN BELT TENSION

A slack fan belt may contribute to overheating, or to insufficient charging of the battery. Inspect the fan belt for damage and wear and adjust it in accordance with the **ISUZU Engine Owner's Manual**.

The fan belt tension is proper if the fan belt bends 10 to 15 mm (Figure 33) when depressed with the thumb as shown below.

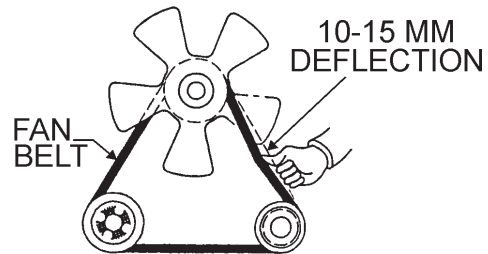

**Figure 33. Fan Belt Tension**

**CAUTION**



**NEVER** place hands near the belts or fan while the generator set is running.



## BATTERY

This unit is of negative ground **DO NOT** connect in reverse. Always maintain battery fluid level between the specified marks. Battery life will be shortened, if the fluid level are not properly maintained. Add only distilled water when replenishment is necessary.

**DO NOT** over fill. Check to see whether the battery cables are loose. Poor contact may result in poor starting or malfunctions. **Always** keep the terminals firmly tightened. Coating the terminals with an approved battery terminal treatment compound. Replace battery with only recommended type battery. The battery type used in this generator is BCI Group 27.

The battery is sufficiently charged if the specific gravity of the battery fluid is 1.28 (at 68° F). If the specific gravity should fall to 1.245 or lower, it indicates that the battery is dead and needs to be recharged or replaced.

Before charging the battery with an external electric source, be sure to disconnect the battery cables.

### Battery Cable Installation

ALWAYS be sure the battery cables (Figure 34) are properly connected to the battery terminals as shown below. The **red cable** is connected to the positive terminal of the battery, and the **black cable** is connected to the negative terminal of the battery.

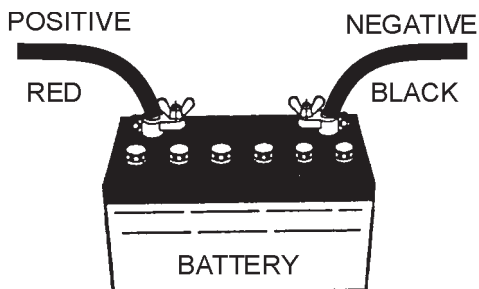
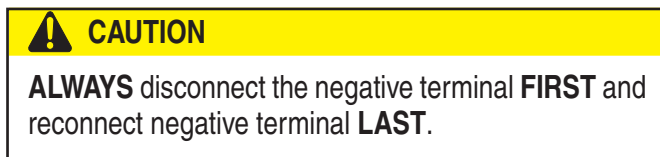

Figure 34. Battery Connections

When connecting battery do the following:

1. **NEVER** connect the battery cables to the battery terminals when the **MPEC Control Switch** is in either the **MANUAL** position. **ALWAYS** make sure that the **MPEC Control Switch** is in the **OFF/RESET** position when connecting the battery.
2. Place a small amount of battery terminal treatment compound around both battery terminals. This will ensure a good connection and will help prevent corrosion around the battery terminals.

### NOTICE

If the battery cable is connected incorrectly, electrical damage to the generator will occur. Pay close attention to the polarity of the battery when connecting the battery.

### CAUTION

Inadequate battery connections may cause poor starting of the generator, and create other malfunctions.

## ALTERNATOR

The polarity of the alternator is negative grounding type. When an inverted circuit connection takes place, the circuit will be in short circuit instantaneously resulting the alternator failure.

**DO NOT** put water directly on the alternator. Entry of water into the alternator can cause corrosion and damage the alternator.

## WIRING

Inspect the entire generator for bad or worn electrical wiring or connections. If any wiring or connections are exposed (insulation missing) replace wiring immediately.

## PIPING AND HOSE CONNECTION

Inspect all piping, oil hose, and fuel hose connections for wear and tightness. Tighten all hose clamps and check hoses for leaks.

If any hose (**fuel or oil**) lines are defective replace them immediately.

# GENERATOR START-UP PROCEDURE (MANUAL)

## BEFORE STARTING

### CAUTION

The engine's exhaust contains harmful emissions. **ALWAYS** have adequate ventilation when operating. Direct exhaust away from nearby personnel.

### WARNING

**NEVER** manually start the engine with the **main, GFCI or auxiliary** circuit breakers in the **ON** (closed) position.

1. Place the **main, G.F.C.I., and aux.** circuit breakers (Figure 35) in the **OFF** position prior to starting the engine.

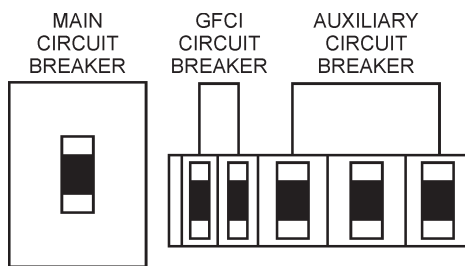

**Figure 35. Main, Aux. and GFCI Circuit Breakers (OFF)**

2. Make sure the **voltage change-over board** has been configured for the desired output voltage.
3. Connect the load to the **receptacles** or the **output terminal lugs** as shown in Figure 10. These load connection points can be found on the output terminal panel and the output terminal panel's hard wire hookup panel.
4. Tighten terminal nuts securely to prevent load wires from slipping out.
5. Close all engine enclosure doors (Figure 36).

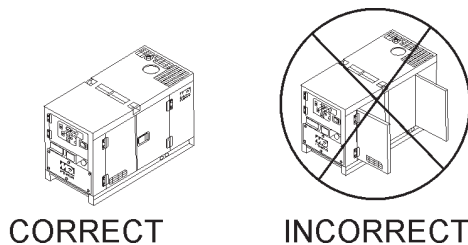

**Figure 36. Engine Enclosure Doors**

## STARTING (MANUAL)

1. Place the engine speed switch (Figure 37) in the **LOW** (down) position.



**Figure 37. Engine Speed Switch (Low)**

2. Place the **MPEC control switch** in the **MANUAL** position to start the engine (Figure 38).



**Figure 38. MPEC Control Switch (Manual Position)**

3. Depending on the temperature of the coolant (cold weather conditions), the pre-heat lamp (Figure 39) will light (ON) and remain on until the pre-heating cycle has been completed. After completion of the pre-heating cycle, the light will go OFF and the engine will start up automatically.

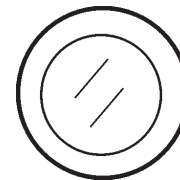

**Figure 39. Pre-Heat Button**

4. Once the engine starts, let the engine run for 1-2 minutes. Listen for any abnormal noises. If any abnormalities exist, shut down the engine and correct the problem. If the engine is running smoothly, place the engine speed switch (Figure 40) in the **HIGH** (up) position.



**Figure 40. Engine Speed Switch (High)**

5. Verify that the **engine running** status LED on the MPEC unit (Figure 41) is **ON** (lit) after the engine has been started.



**Figure 41. Engine Running LED (ON)**

# GENERATOR START-UP PROCEDURE (MANUAL)

6. The generator's frequency meter (Figure 42) should be displaying the 60 cycle output frequency in **HERTZ**.

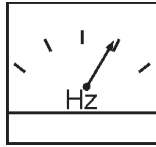

**Figure 42. Frequency Meter**

7. The generator's AC-voltmeter (Figure 43) will display the generator's output in **VOLTS**. If the voltage is not within the specified tolerance, use the voltage adjustment control knob (Figure 44) to increase or decrease the desired voltage.

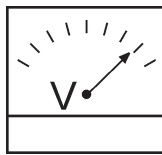
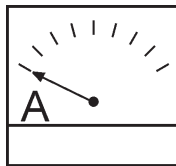

**Figure 43. Voltmeter**



**Figure 44. Voltage Adjust Control Knob**

8. The ammeter (Figure 45) will indicate **zero amps** with no load applied. When a load is applied, the ammeter will indicate the amount of current that the load is drawing from the generator.



**Figure 45. Ammeter (No Load)**

9. The engine oil pressure gauge (Figure 46) will indicate the oil pressure of the engine. Under normal operating conditions the oil pressure is approximately 28 to 85 psi. (193~586 kPa).

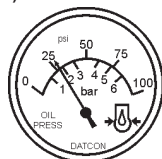
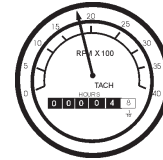

**Figure 46. Oil Pressure Gauge**

10. The **coolant temperature gauge** (Figure 47) will indicate the coolant temperature. Under normal operating conditions the coolant temperature should be between 167°~203°F (75°~95°C) (**Green Zone**).

**Figure 47. Coolant Temperature Gauge**

11. The **tachometer gauge** (Figure 48) will indicate the speed of the engine when the generator is operating. Under normal operating conditions this speed is approximately 1800 RPM's.



**Figure 48. Engine Tachometer Gauge**

12. Place the **main, GFCI, and aux.** circuit breakers in the **ON** position (Figure 49).

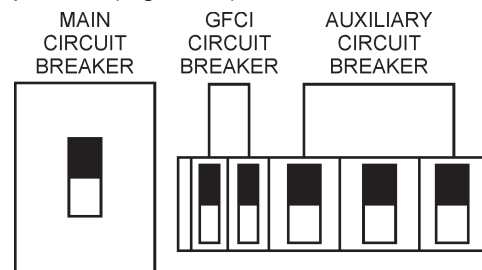

**Figure 49. Main, Aux. and GFCI Circuit Breakers (ON)**

13. Observe the generator's ammeter (Figure 50) and verify it reads the anticipated amount of current with respect to the load. The ammeter will only display a current reading if a load is in use.

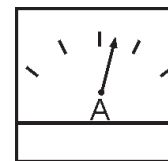

**Figure 50. Ammeter (Load)**

14. The generator will run until manually stopped or an abnormal condition occurs.

# GENERATOR START-UP PROCEDURE (AUTO MODE)

## STARTING (AUTO MODE)

### DANGER



Before connecting this generator to any building's electrical system, a **licensed electrician** must install an **isolation (transfer) switch**. Serious damage to the building's electrical system may occur without this transfer switch.

### CAUTION

When connecting the generator to a isolation (transfer) switch, **ALWAYS** have power applied to the generator's internal battery charger. This will ensure that the engine will not fail due to a dead battery.

### NOTICE

When the generator is set in the **AUTO** mode, the generator will **automatically start** in the event of commercial power falling below a prescribed level by means of a contact closure that is generated automatically by a transfer switch.

### WARNING

When running the generator in the **AUTO** mode, remember the generator can start up at any time without warning. **NEVER** attempt to perform any maintenance when the generator is in the auto mode.

### CAUTION

The engine speed switch **must** be set to the "High" position when running in the **auto-start** mode. Failing to set the switch in the proper position can result in damage to your generator when it turns on.

### NOTICE

When the MPEC control switch is placed in the **AUTO** position, the engine glow plugs will be warmed and the engine will start automatically.

When starting generator in **AUTO** mode use the "Manual Start-up" procedure except where noted (see below).

1. Perform steps 1 through 5 in the Before Starting section as outlined in the Manual Starting Procedure.
2. Place the **engine speed switch** (Figure 51) in the **HIGH** position



**Figure 51. Engine Speed Switch (High)**

3. Place the **MPEC Control Switch** (Figure 52) in the **AUTO** position.



**Figure 52. MPEC Control Switch (AUTO)**

4. Continue operating the generator as outlined in the Manual Start-up procedure (start at step 5).

# GENERATOR SHUT-DOWN PROCEDURES

## WARNING

**NEVER** stop the engine suddenly except in an emergency.

### NORMAL SHUTDOWN PROCEDURE

To shutdown the generator, use the following procedure:

1. Place both the **MAIN, GFCI and LOAD** circuit breakers as shown in Figure 35 to the **OFF** position.
2. Place the engine speed switch (Figure 53) in the “LOW” (down) position.



**Figure 53. Engine Speed Switch (Low)**

3. Let the engine cool by running it at low speed for 3-5 minutes with no load applied.
4. Place the **MPEC Control Switch** (Figure 54) to the **OFF/RESET** position.

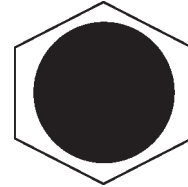

**Figure 54. MPEC Control Switch (Off/Reset)**

5. Verify that **all** the status LEDs on the MPEC display are **OFF** (not lit).
6. Remove all loads from the generator.
7. Inspect entire generator for any damage or loosening of components that may have occurred during operation.

### EMERGENCY SHUTDOWN PROCEDURE

1. To stop the engine in the event of an emergency, **PUSH** the emergency stop button (Figure 55) inward. This button is located on the engine operating panel, see Figure 5.



**Figure 55. Emergency Stop Button**

Table 14. Inspection/Maintenance		10 Hrs DAILY	250 Hrs	500 Hrs	1000 Hrs
<b>Engine</b>	Check Engine Fluid Levels	X			
	Check Air Cleaner	X			
	Check Battery Acid Level	X			
	Check Fan Belt Condition	X			
	Check for Leaks	X			
	Check for Loosening of Parts	X			
	Replace Engine Oil and Filter * 1		X		
	Clean Air Filter		X		
	Check Fuel Filter/Water Separator Bowl	X			
	Clean Unit, Inside and Outside		X		
	Change Fuel Filter			X	
	Clean Radiator and Check Coolant Protection Level*2			X	
	Replace Air Filter Element * 3			X	
	Check all Hoses and Clamps * 4				X
	Clean Inside of Fuel Tank				X
<b>Generator</b>	Measure Insulation Resistance Over 3M ohms		X		
	Check Rotor Rear Support Bearing			X	

\*1 Replace engine oil and filter at 100 hours, first time only.

\*2 Add "Supplemental Coolant Additives (SCA'S)" to recharge the engine coolant.

\*3 Replace primary air filter element when restriction indicator shows a vacuum of 625 mm (25 in. H2O).

\*4 If blowby hose needs to be replaced, ensure that the slope of the blowby hose is at least a 1/2 inch per foot, with no sags or dips that could collect moisture and/or oil.

## GENERAL INSPECTION

Prior to each use, the generator should be cleaned and inspected for deficiencies. Check for loose, missing or damaged nuts, bolts or other fasteners. Also check for fuel, oil, and coolant leaks. Use Table 14 as a general maintenance guideline **Engine Side** (Refer to the Engine Instruction Manual)

### AIR CLEANER

Every 250 hours: Remove air cleaner element (Figure 56) and clean the heavy duty paper element with light spray of compressed air. Replace the air cleaner as needed.

#### Air Cleaner with Dust Indicator

This indicator (Figure 56) is attached to the air cleaner. When the air cleaner element is clogged, air intake restriction becomes greater and the dust indicator signal shows **RED** meaning the element needs changing or service. After changing the air element, press the dust indicator button to reset the indicator.

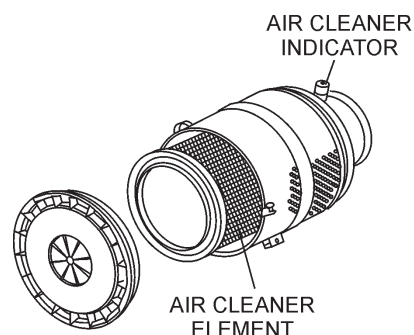

**Figure 56. Air Cleaner/Indicator**

#### NOTICE

The air filter should not be changed until the indicator reads "**RED**". Dispose of old air filter. It may not be cleaned or reused.

If the engine is operating in very **dusty** or **dry grass** conditions, a clogged air cleaner will result. This can lead to a loss of power, excessive carbon buildup in the combustion chamber and high fuel consumption. Change air cleaner more **frequently** if these conditions exist.

## FUEL ADDITION

Add diesel fuel (the grade may vary according to season and locations).

## Removing Water from the Fuel Tank

After prolonged use, water and other impurities accumulate in the bottom of the tank. Occasionally inspect the fuel tank for water contamination and drain the contents if required.

During cold weather, the more empty volume inside the tank, the easier it is for water to condense. This can be reduced by keeping the tank full with diesel fuel.

## Cleaning Inside the Fuel Tank

Drain the fuel inside the fuel tank completely. Using a spray washer (Figure 57) wash out any deposits or debris that have accumulated inside the fuel tank.

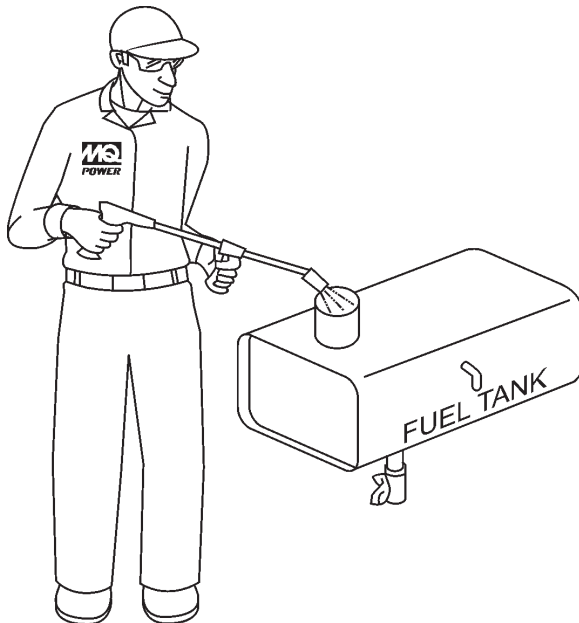

Figure 57. Fuel Tank Cleaning

## FUEL TANK INSPECTION

In addition to cleaning the fuel tank, the following components should be inspected for wear:

- **Rubber Suspension** — look for signs of wear or deformity due to contact with oil. Replace the rubber suspension if necessary.
- **Fuel Hoses** — inspect nylon and rubber hoses for signs of wear, deterioration and hardening.
- **Fuel Tank Lining** — inspect the fuel tank lining for signs of excessive amounts of oil or other foreign matter.

## Replacing Fuel Filter

- Replace the fuel filter cartridge with new one every 500 hours or so.
- Loosen the drain plug at the lower top of the fuel filter. Drain the fuel in the fuel body together with the mixed water. **DO NOT** spill the fuel during disassembly.
- Vent any air

## AIR REMOVAL

If air enters the fuel injection system of a diesel engine, starting becomes impossible. After running out of fuel, or after disassembling the fuel system, bleed the system according to the following procedure. See the **ISUZU Engine Manual** for details.

To restart after running out of fuel, turn the switch to the "ON" position for 15-30 seconds. Try again, if needed. This unit is equipped with an automatic air bleeding system.

## CHECK OIL LEVEL

Check the crankcase oil level prior to each use, or when the fuel tank is filled. Insufficient oil may cause severe damage to the engine. Make sure the generator is level. The oil level must be between the two notches on the dipstick as shown in Figure 27.

## Replacing Oil Filter

- Remove the old oil filter.
- Apply a film of oil to the gasket on the new oil filter.
- Install the new oil filter.
- After the oil cartridge has been replaced, the engine oil will drop slightly. Run the engine for a while and check for leaks before adding more oil if needed. Clean excessive oil from engine.

## FLUSHING OUT RADIATOR AND REPLACING COOLANT

- Open both cocks located at the crankcase side and at the lower part of the radiator and drain coolant. Open the radiator cap while draining. Remove the overflow tank and drain.
- Check hoses for softening and kinks. Check clamps for signs of leakage.
- Tighten both cocks and replace the overflow tank.
- Replace with coolant as recommended by the engine manufacturer.
- Close radiator cap tightly.
- Flush the radiator by running clean tap water through radiator until signs of rust and dirt are removed. **DO NOT** clean radiator core with any objects, such as a screwdriver.

### WARNING



Allow engine to **cool** when flushing out radiator. Flushing the radiator while hot could cause serious burns from water or steam.

## RADIATOR CLEANING

The radiator (Figure 58) should be sprayed (cleaned) with a high pressure washer when excessive amounts of dirt and debris have accumulated on the cooling fins or tube. When using a high pressure washer, stand at least 5 feet (1.5 meters) away from the radiator to prevent damage to the fins and tube.

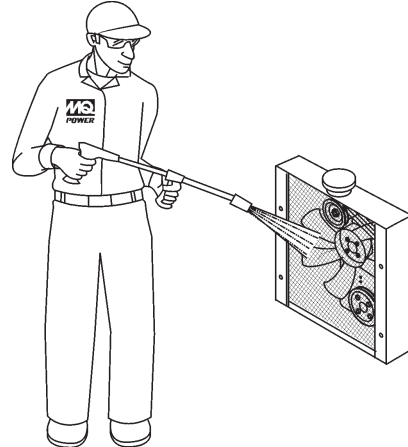

Figure 58. Radiator Cleaning

## GENERATOR STORAGE

For long term storage of the generator the following is recommended:

- Drain the fuel tank completely. Treat with a fuel stabilizer if necessary.
- Completely drain the oil from the crankcase and refill if necessary with fresh oil.
- Clean the entire generator, internal and external.
- Cover the generating set and store in a clean, dry place.
- Disconnect the battery.
- Make sure engine coolant is at proper level.
- If generator is mounted on a trailer, jack trailer up and place on blocks so tires do not touch the ground or block and completely remove the tires.

## JACKET WATER HEATER AND INTERNAL BATTERY CHARGER 120 VAC INPUT RECEPTACLES (OPTIONAL)

This generator can be optionally equipped with two 120 VAC, 20 amp input receptacles located on the output terminal panel.



The purpose of these receptacles is to provide power via commercial power to the **jacket water heater** and **internal battery charger**.

These receptacles will **ONLY** function when commercial power has been supplied to them (Figure 59). To apply commercial power to these receptacles, a power cord of adequate size will be required (See Table 6).

When using the generator in **hot** climates there is no reason to apply power to jacket water heater. However, if the generator will be used in **cold** climates it is always a good idea to apply power to the jacket water heater at all times. To apply power to the jacket water heater simply apply power to the jacket water heater receptacle via commercial power using an power cord of adequate size.

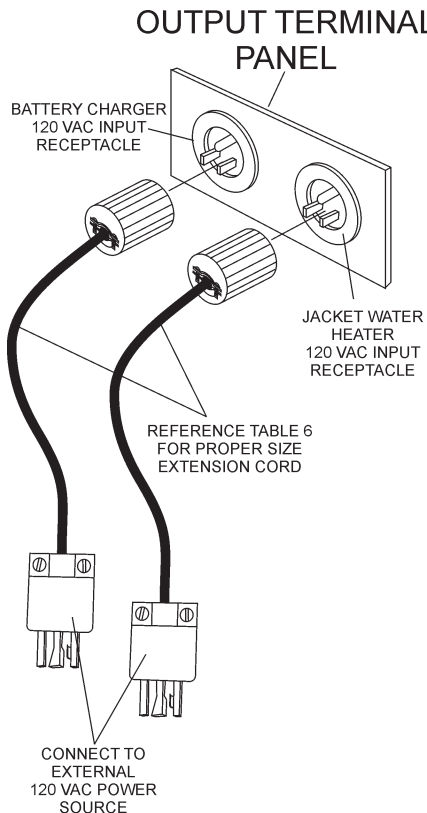

**Figure 59. Battery Charger and Jacket Water Heater Power Connections**

If the generator will be used daily, the battery should normally not require charging. If the generator will be idle

**NOTICE**  
To ensure adequate charging capability, always have power applied to the generator's internal battery charger.

# TRAILER MAINTENANCE

---

## TRAILER MAINTENANCE

This section is intended to provide the user with generic trailer service and maintenance information. The service and maintenance guidelines referenced in this section refer to a wide range of trailers.

Remember periodic inspection of the trailer will ensure safe towing of the generator and will prevent personal injury and damage to the equipment.

The definitions below describe some of the major components of a typical trailer that would be used with the DCA400SSI Whisperwatt™ Generator.

1. **Fuel Cell** — Provides an adequate amount of fuel for the equipment in use. Fuel cells must be empty when transporting equipment.
2. **Braking System** — System employed in stopping the trailer. Typical braking systems are electric, surge, hydraulic, hydraulic-surge and air.
3. **GVWR** — Gross Vehicle Weight Rating (GVWR) is the maximum number of pounds the trailer can carry, including the fuel cell (empty).
4. **Frame Length** — Measurement is from the ball hitch to the rear bumper (reflector).
5. **Frame Width** — Measurement is from fender to fender
6. **Jack Stand** — Trailer support device with maximum pound requirement from the tongue of the trailer.
7. **Coupler** — Type of hitch used on the trailer for towing.
8. **Tire Size** — Indicates the diameter of the tire in inches (10,12,14, etc.), and the width in millimeters (175,185,205, etc.). The tire diameter must match the diameter of the tire rim.
9. **Tire Ply** — The tire ply (layers) number is rated in letters; 2-ply,4-ply,6-ply, etc.
10. **Wheel Hub** — The wheel hub is connected to the trailer's axle.
11. **Tire Rim** — Tires mounted on a tire rim. The tire rim must match the size of the tire.
12. **Lug Nuts** — Used to secure the wheel to the wheel hub. Always use a torque wrench to tighten down the lug nuts. See Table 18 and Figure 62 for lug nut tightening and sequence.
13. **Axle** — Indicates the maximum weight the axle can support in pounds, and the diameter of the axle expressed in inches. Please note that some trailers have a double axle. This will be shown as 2-6000 lbs., meaning two axles with a total weight capacity of 6000 pounds.
14. **Suspension** — Protects the trailer chassis from shocks transmitted through the wheels. Types of suspension used are leaf, Q-flex, and air ride.
15. **Electrical** — Electrical connectors (looms) are provided with the trailer so the brake lights and turn signals can be connected to the towing vehicle.
16. **Application** — Indicates which units can be employed on a particular trailer.

## BRAKES

Trailer brakes should be inspected the **first 200 miles** of operation. This will allow the brake shoes and drums to seat properly. After the first 200 mile interval, inspect the brakes **every 3,000 miles**. If driving over rough terrain, inspect the brakes more frequently.

Figure 60 displays the major hydraulic surge brake components that will require inspection and maintenance. Please inspect these components as required using steps 1 through 8 and Table 15 as listed below:

### Brake Adjustment

1. Place the trailer on jack stands. Make sure the jack stands are placed on secure level ground.
2. Check the wheel and drum for free rotation.
3. Remove the adjusting hole cover from the adjusting slot at the bottom brake backing plate.
4. With a screwdriver or standard adjusting tool, rotate the star wheel of the adjuster assembly to expand the brake shoes.
5. Adjust the brake shoes outward until the pressure of the lining against the wheel drum makes the wheel difficult to turn.
6. Adjust, rotate the star wheel in the opposite direction until the wheel rotates freely with slight lining drag.
7. Replace the adjusting hole cover and lower the trailer to the ground.
8. Repeat steps 1 through 7 on the remaining brakes.

## Hydraulic Surge Brakes

Hydraulic surge brakes (Figure 60) should not require any special attention with the exception of routine maintenance such as shoe and lining replacement. Brake lines should be periodically checked for cracks, kinks, or blockage.

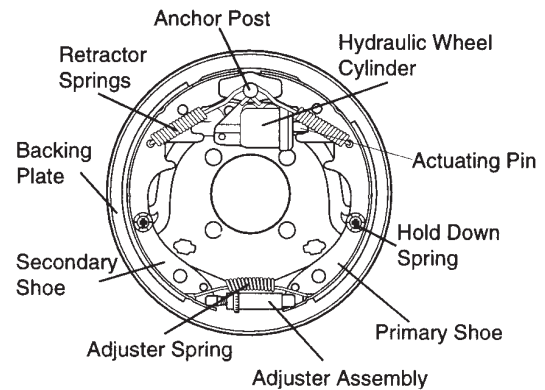

**Figure 60. Hydraulic Brake Components**

### Actuator

Hydraulic surge braking requires the installation of an actuator at the tongue of the trailer. Remember the **surge or push** of the trailer toward the tow vehicle automatically synchronizes the trailer brakes with the tow vehicle brakes. As the trailer pushes against the tow vehicle the actuator telescopes together and applies force to the master cylinder, supplying hydraulic pressure to the trailer brakes.

Periodically check and test the surge “actuator” to make sure that it is functioning correctly. Never use an undersize actuator.

**Table 15. Hydraulic Brake Troubleshooting**

Symptom	Possible Cause	Solution
No Brakes	Brake line broken or kinked?	Repair or replace.
Weak Brakes or Brakes Pull to One Side	Brake lining glazed?	Reburnish or replace.
	Trailer overloaded?	Correct weight.
	Brake drums scored or grooved?	Machine or replace.
	Tire pressure correct?	Inflate all tires equally.
	Tires unmatched on the same axle?	Match tires.
Locking Brakes	Brake components loose, bent or broken?	Replace components.
	Brake drums out-of-round?	Replace.
Noisy Brakes	System lubricated?	Lubricate.
	Brake components correct?	Replace and correct.
Dragging Brakes	Brake lining thickness incorrect or not adjusted correctly?	Install new shoes and linings.
	Enough brake fluid or correct fluid?	Replace rubber parts fill with dot 4 fluid.

# TRAILER MAINTENANCE

## TIRES/WHEELS/LUG NUTS

Tires and wheels are a very important and critical components of the trailer. When specifying or replacing the trailer wheels it is important the wheels, tires, and axle are properly matched.

**CAUTION**



**ALWAYS** wear safety glasses when removing or installing force fitted parts. Failure to comply may result in serious injury.

**CAUTION**









**DO NOT** attempt to repair or modify a wheel. **DO NOT** install in inner tube to correct a leak through the rim. If the rim is cracked, the air pressure in the inner tube may cause pieces of the rim to explode (break off) with great force and cause serious eye or bodily injury.

## Tire Wear/Inflation

Tire inflation pressure is the most important factor in tire life. Pressure should be checked cold before operation **DO NOT** bleed air from tires when they are **hot!** Check inflation pressure weekly during use to insure the maximum tire life and tread wear.

Table 16 (Tire Wear Troubleshooting) will help pinpoint the causes and solutions of tire wear problems.

Table 16. Tire Wear Troubleshooting			
Wear Pattern	Cause	Solution	
	Center Wear	Over inflation.	Adjust pressure to particular load per tire manufacturer.
	Edge Wear	Under inflation.	Adjust pressure to particular load per tire manufacturer.
	Side Wear	Loss of camber or overloading.	Make sure load does not exceed axle rating. Align wheels.
	Toe Wear	Incorrect toe-in.	Align wheels.
	Cupping	Out-of-balance.	Check bearing adjustment and balance tires.
	Flat Spots	Wheel lockup and tire skidding.	Avoid sudden stops when possible and adjust brakes.

## Suspension

The **leaf suspension** springs and associated components (Figure 61) should be visually inspected every 6,000 miles for signs of excessive wear, elongation of bolt holes, and loosening of fasteners. Replace all damaged parts (suspension) immediately. Torqued suspension components as detailed in Table 17.

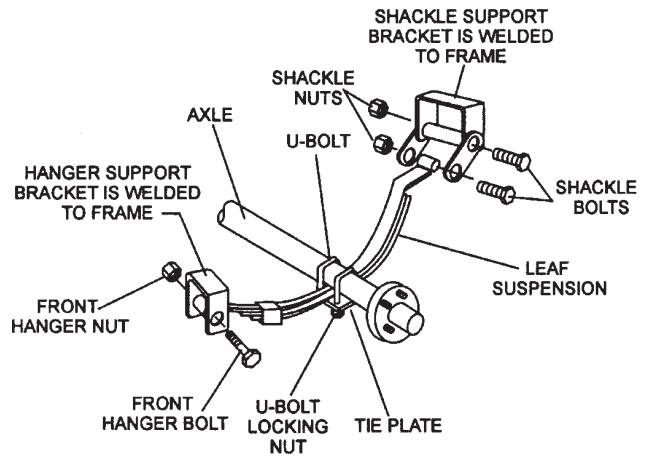

Figure 61. Major Suspension Components

Table 17. Suspension Torque Requirements	
Item	Torque (Ft.-Lbs.)
3/8" U-Bolt	Min-30 Max-35
7/16" U-Bolt	Min-45 Max-60
1/2" U-Bolt	Min-45 Max-60
Shackle Bolt Spring Eye Bolt	Snug fit only. Parts must rotate freely. Locking nuts or cotter pins are provided to retain nut-bolt assembly.
Shoulder Type Shackle Bolt	Min-30 Max-50

# TRAILER MAINTENANCE

## Lug Nut Torque Requirements

It is extremely important to apply and maintain proper wheel mounting torque on the trailer. Be sure to use only the fasteners matched to the cone angle of the wheel. Proper procedure for attachment of the wheels is as follows:

1. Start all wheel lug nuts by hand.
2. Torque all lug nuts in sequence (see Figure 62). **DO NOT** torque the wheel lug nuts all the way down. Tighten each lug nut in 3 separate passes as defined by Table 18.
3. After first road use, retorque all lug nuts in sequence. Check all wheel lug nuts periodically.

Table 18. Tire Torque Requirements			
Wheel Size	First Pass FT-LBS	Second Pass FT-LBS	Third Pass FT-LBS
12"	20-25	35-40	50-65
13"	20-25	35-40	50-65
14"	20-25	50-60	90-120
15"	20-25	50-60	90-120
16"	20-25	50-60	90-120

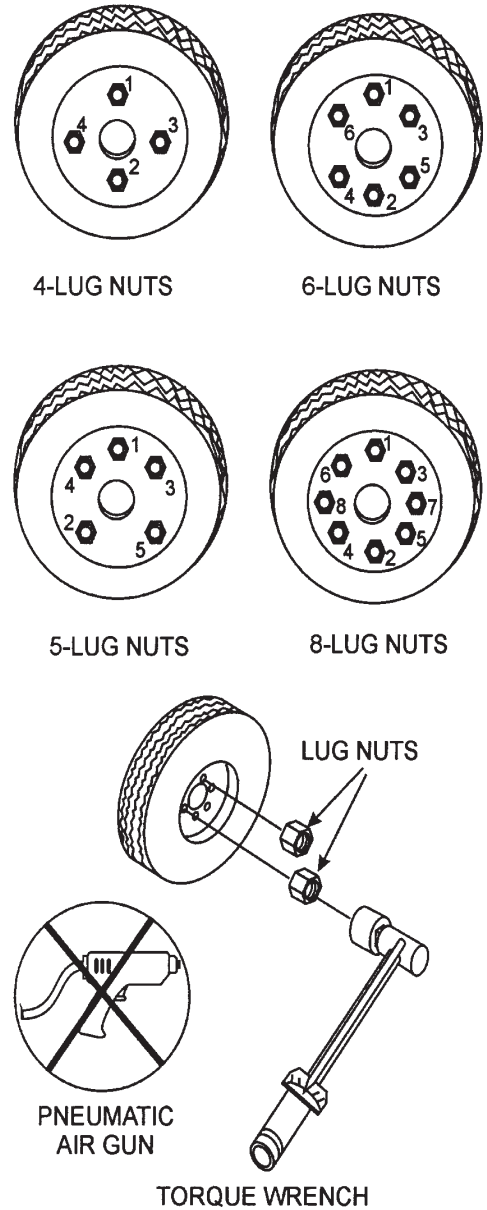

**Figure 62. Wheel Lug Nuts Tightening Sequence**

### NOTICE

**NEVER** use an pneumatic air gun to tighten wheel lug nuts.

# TRAILER WIRING DIAGRAM

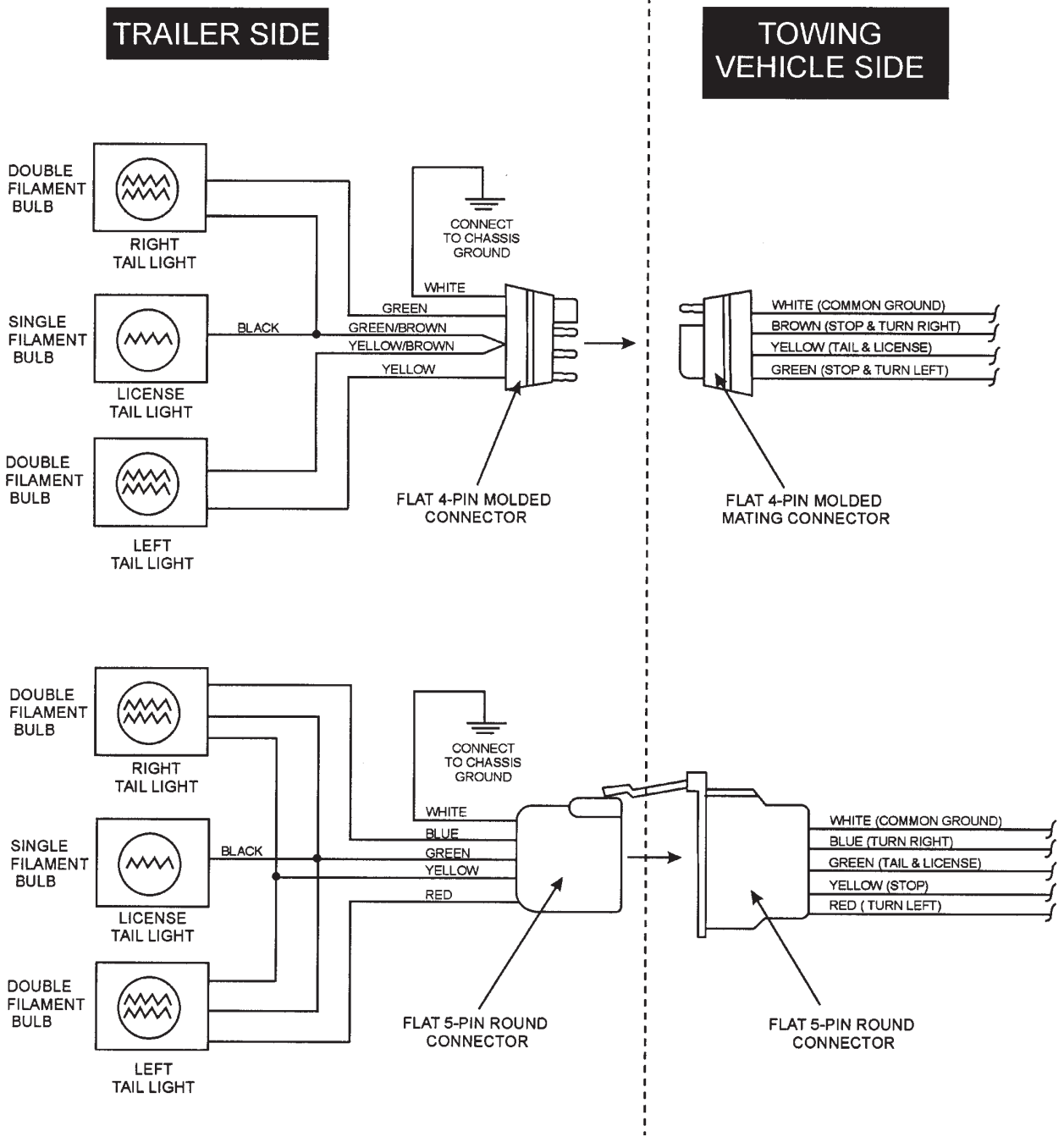

Figure 63. Trailer/Towing Vehicle Wiring Diagram

# GENERATOR WIRING DIAGRAM

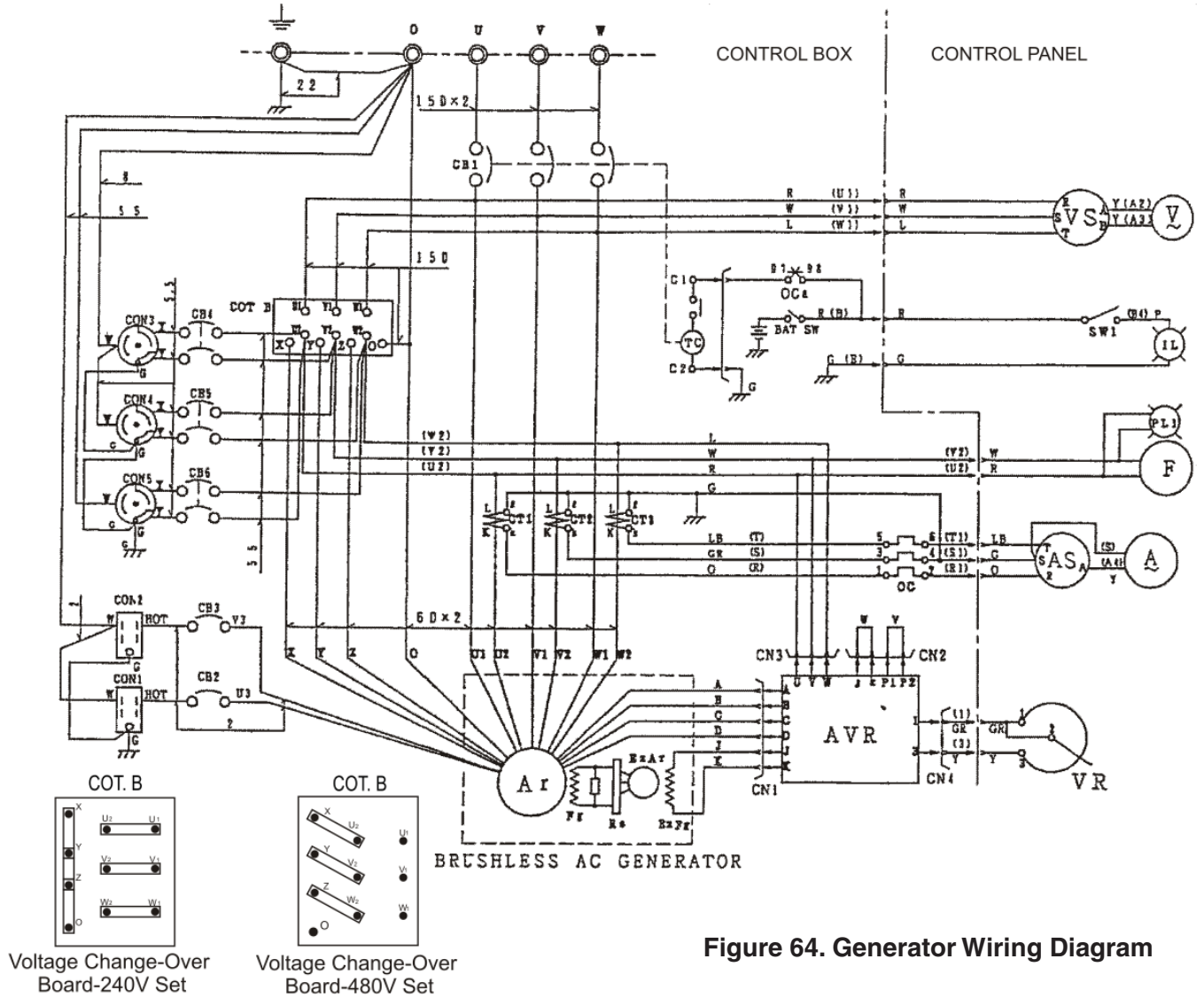
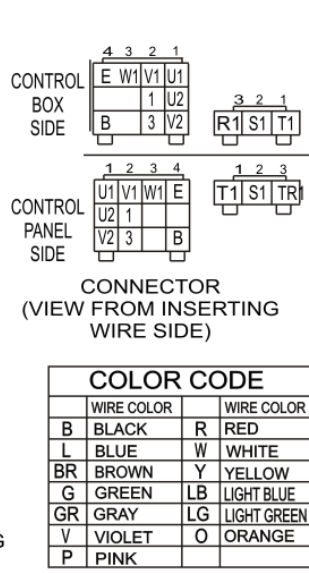
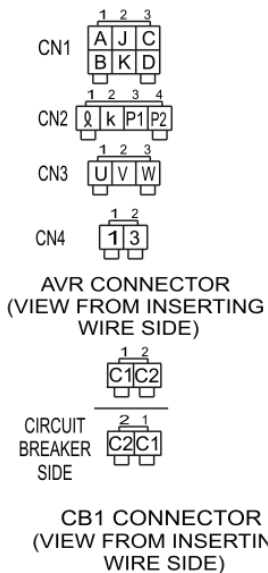

Figure 64. Generator Wiring Diagram



SYMBOL	DESIGNATION	SYMBOL	DESIGNATION
Ar	ARMATURE WINDING	A	AC AMMETER 0-750, 1,500A
Fg	MAIN GENERATOR FIELD WINDING	VS	VOLTMETER CHANGE-OVER SWITCH
Ex Ar	EXCITER ARMATURE WINDING	V	AC VOLTMETER 0-600V
Ex Fg	EXCITER FIELD WINDING	F	FREQUENCY METER 45-65 Hz
AVR	AUTOMATIC VOLTAGE REGULATOR	PL1	PILOT LAMP
VR	VOLTAGE REGULATING RHEOSTAT	CB2-3	AUX. CIRCUIT BREAKER 20A
Re	RECTIFIER	CB4-6	AUX. CIRCUIT BREAKER 50A
CT1-3	CURRENT TRANSFORMER 750/5A	CON2-3	RECEPTACLE 520R GFCI 20A, 125V
CB1	CIRCUIT BREAKER 1,000 AMPS	CON3-5	RECEPTACLE CS-6369 50A, 120/240V
OC	OVER CURRENT RELAY	IL	PANEL LIGHT
COT. B	VOLTAGE CHANGE-OVER BOARD	SW1	PANEL LIGHT SWITCH
AS	AMMETER CHANGE-OVER SWITCH		

# ENGINE WIRING DIAGRAM

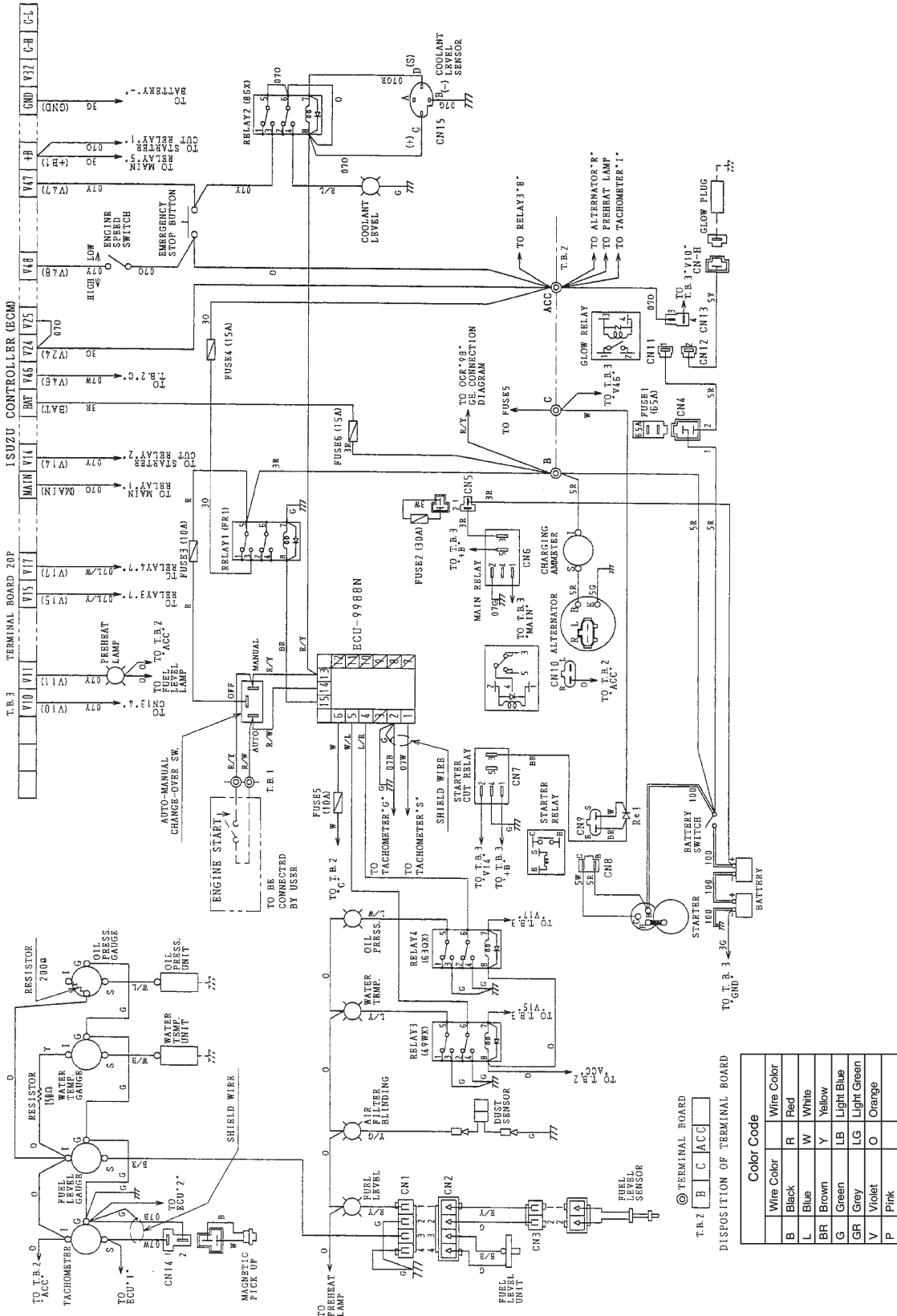

Figure 65. Engine Wiring Diagram



# CONTROLLER WIRING DIAGRAM

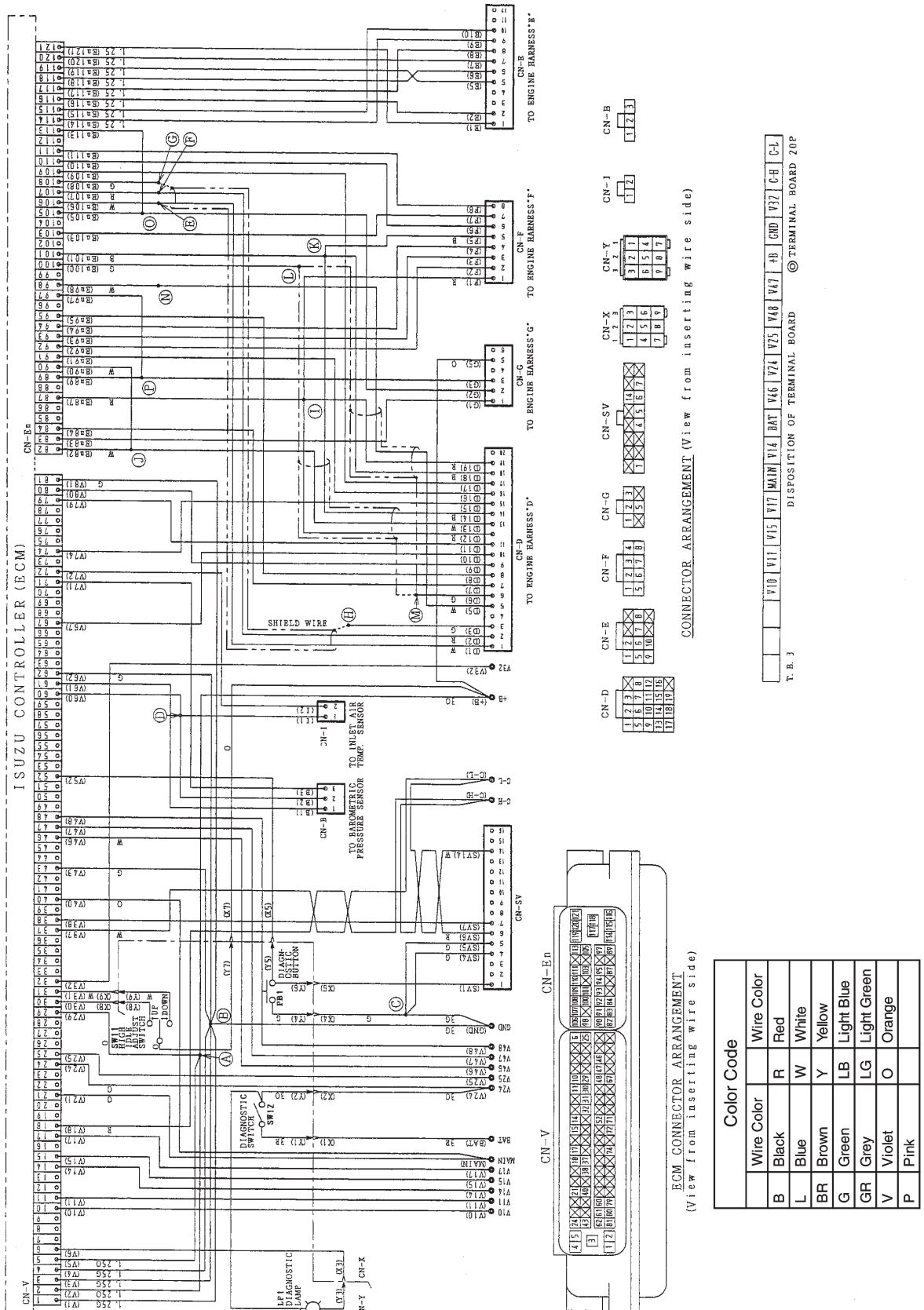

Figure 66. Controller Wiring Diagram

## TROUBLESHOOTING (GENERATOR)

Practically all breakdowns can be prevented by proper handling and maintenance inspections, but in the event of a breakdown, use Table 19 shown below for diagnosis of the Generator. If the problem cannot be remedied, consult our company's business office or service plant.

<b>Table 19. Generator Troubleshooting</b>		
<b>Symptom</b>	<b>Possible Problem</b>	<b>Solution</b>
No Voltage Output	AC Voltmeter defective?	Check output voltage using a voltmeter.
	Is wiring connection loose?	Check wiring and repair.
	Is AVR defective?	Replace if necessary.
	Defective Rotating Rectifier?	Check and replace.
	Defective Exciter Field?	Check for approximately 19 ohms across J & K on CN1
Low Voltage Output	Is engine speed correct?	Turn engine throttle lever to "High".
	Is wiring connections loose?	Check wiring and repair.
	Defective AVR?	Replace if necessary.
High Voltage Output	Is wiring connections loose?	Check wiring and repair.
	Defective AVR?	Replace if necessary.
Circuit Breaker Tripped	Short Circuit in load?	Check load and repair.
	Over current?	Confirm load requirements and reduce.
	Defective circuit breaker?	Check and replace.
	Over current Relay actuated?	Confirm load requirement and replace.

## TROUBLESHOOTING (ENGINE CONTROLLER)

Practically all breakdowns can be prevented by proper handling and maintenance inspections, but in the event of a breakdown, use Table 20 (Engine Controller Troubleshooting) as a basic guideline for troubleshooting the Microprocessor Engine Controller unit (MPEC). If the problem cannot be remedied, consult our company's business office or service plant.

<b>Table 20. Engine Controller Troubleshooting (MPEC)</b>		
Symptom	Possible Problem	Solution
Low oil pressure light is on.	Low oil level?	Fill oil level.
	Oil pressure sending unit failure?	Replace oil pressure sending unit.
	Time delay malfunction in controller?	Refer to dealer.
	Wire shorted?	Inspect/repair wire.
Low coolant level light is on. (Optionally installed)	Low coolant level?	Fill coolant level.
	Sending unit failure?	Replace sending unit.
	Low battery voltage?	Replace/charge battery.
High coolant temperature light is on.	Fan belt tension incorrect?	Tighten/replace fan belt.
	Air flow is not circulating through radiator?	Clean/repair radiator grill.
	Doors open?	Close doors.
	Exhaust leaking?	Replace/repair gaskets or faulty part.
	Generator being overloaded?	Check/reduce load.
	Thermostat failure?	Replace thermostat.
	Air intake blocked?	Clean all air intakes.
Overcrank light is on.	Temperature switch failure	Replace temperature switch.
	No or low fuel?	Fill fuel level.
Overspeed light is on.	Controller needs to be calibrated?	Refer to dealer.
	RPM engine speed too high?	Adjust RPM.
	Governor actuator needs to be adjusted?	Adjust governor actuator.
	Governor controller needs to be adjusted?	Adjust governor controller.
Loss of MPU light(s) or on.	Engine controller needs to be calibrated?	Refer to dealer.
	Magnetic pick up out of adjustment?	Adjust magnetic pick up.
	Magnetic pick up dirty?	Clean magnetic pick up.

## TROUBLESHOOTING (DIAGNOSTIC LAMP)

The engine controller of this generator diagnoses problems that arise from the engine control system and the engine itself. Press the diagnostic button (Figure 67) on the diagnostic panel to determine if an engine malfunction has occurred.

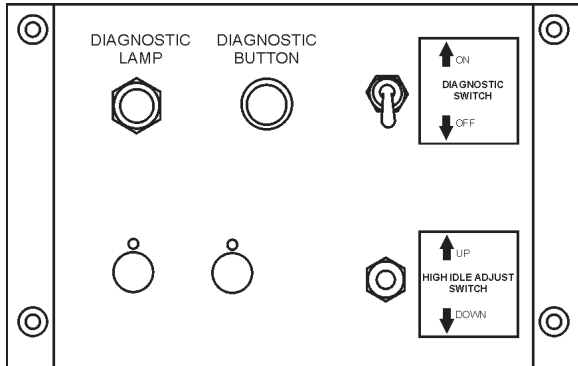

Figure 67. Diagnostic Panel

### METHOD OF OPERATION

1. Normally, the diagnostic lamp will be **dimly** lit when the **MPEC Control Switch** is placed in the **MANUAL** position.
2. If engine trouble occurs, the diagnostic lamp will be **brightly** lit as long as the control switch is left in the manual position.
3. The diagnostic lamp will indicate that an engine malfunction has occurred.

#### NOTICE

For a complete understanding of error codes and troubleshooting procedures, refer to the enclosed engine instruction manual.

#### NOTICE

If the engine is cranked while the diagnostic switch is in the "ON" position, the engine will not be stopped even if the starter switch is turned to the "OFF" position. In such case, turn the diagnostic switch to the "OFF" position.



# EXPLANATION OF CODE IN REMARKS COLUMN

The following section explains the different symbols and remarks used in the Parts section of this manual. Use the help numbers found on the back page of the manual if there are any questions.

The contents and part numbers listed in the parts section are subject to change **without notice**. Multiquip does not guarantee the availability of the parts listed.

Sample Parts List:

NO.	PART NO.	PART NAME	QTY.	REMARKS
1	12345	BOLT .....	1	INCLUDES ITEMS W/*
2*		WASHER, 1/4 IN. ....		NOT SOLD SEPARATELY
2*	12347	WASHER, 3/8 IN. ...	1	MQ-45T ONLY
3	12348	HOSE .....	A/R	MAKE LOCALLY
4	12349	BEARING .....	1	S/N 2345B AND ABOVE

## NO. Column

**Unique Symbols** - All items with same unique symbol (\*, #, +, %, or >) in the number column belong to the same assembly or kit, which is indicated by a note in the "Remarks" column.

**Duplicate Item Numbers** - Duplicate numbers indicate multiple part numbers are in effect for the same general item, such as different size saw blade guards in use or a part that has been updated on newer versions of the same machine.



When ordering a part that has more than one item number listed, check the remarks column for help in determining the proper part to order.

## PART NO. Column

**Numbers Used** - Part numbers can be indicated by a number, a blank entry, or TBD.

TBD (To Be Determined) is generally used to show a part that has not been assigned a formal part number at time of publication.

A blank entry generally indicates that the item is not sold separately or is not sold by Multiquip. Other entries will be clarified in the "Remarks" Column.

## QTY. Column

**Numbers Used** - Item quantity can be indicated by a number, a blank entry, or A/R.

A/R (As Required) is generally used for hoses or other parts that are sold in bulk and cut to length.

A blank entry generally indicates that the item is not sold separately. Other entries will be clarified in the "Remarks" Column.

## REMARKS Column

Some of the most common notes found in the "Remarks" Column are listed below. Other additional notes needed to describe the item can also be shown.

**Assembly/Kit** - All items on the parts list with the same unique symbol will be included when this item is purchased.

Indicated by:

"INCLUDES ITEMS W/(unique symbol)"

**Serial Number Break** - Used to list an effective serial number range where a particular part is used.

Indicated by:

"S/N XXXXX AND BELOW"

"S/N XXXX AND ABOVE"

"S/N XXXX TO S/N XXX"

**Specific Model Number Use** - Indicates that the part is used only with the specific model number or model number variant listed. It can also be used to show a part is NOT used on a specific model or model number variant.

Indicated by:

"XXXXX ONLY"

"NOT USED ON XXXX"

**"Make/Obtain Locally"** - Indicates that the part can be purchased at any hardware shop or made out of available items. Examples include battery cables, shims, and certain washers and nuts.

**"Not Sold Separately"** - Indicates that an item cannot be purchased as a separate item and is either part of an assembly/kit that can be purchased, or is not available for sale through Multiquip.

## SUGGESTED SPARE PARTS

### DCA400SSI WHISPERWATT GENERATOR WITH ISUZU 6WG1X DIESEL ENGINE

1 to 3 units

QTY.	P/N	DESCRIPTION
1.....	C3310500003.....	HOSE, RADIATOR UPPER
1.....	C3310500103.....	HOSE, RADIATOR LOWER
1.....	.0602011059.....	RADIATOR CAP
1.....	.0845500104.....	FUEL CAP
3.....	.0602015252.....	V-BELT SET
1.....	.8972177780.....	OIL PRESSURE SENSOR, ENGINE
1.....	.0602122272.....	OIL PRESSURE UNIT
1.....	.0602123267.....	WATER TEMPERATURE UNIT
1.....	.8973639360.....	WATER TEMP. SENSOR, ENGINE
1.....	.1802200140.....	BOOST SENSOR
1.....	.0602123290.....	SWITCH, COOLANT LEVEL
6.....	.0810105400.....	FILTER, FUEL TANK
6.....	.0602042405.....	FILTER, FUEL PRIMARY
6.....	.0602042516.....	ELEMENT PRIMARY FUEL FILTER
6.....	.0602042515.....	ELEMENT, MAIN FUEL FILTER
6.....	.0602041219.....	FILTER, OIL CARTRIDGE, MAIN
6.....	.0602041220.....	FILTER, OIL CARTRIDGE, BYPASS
3.....	.0602046628.....	ELEMENT AIR CLEANER OUTER
3.....	.0602046629.....	ELEMENT AIR CLEANER INNER
1.....	.0601808803.....	CIRCUIT BREAKER 1P 20A
1.....	.0601808804.....	CIRCUIT BREAKER 2P 50A
2.....	.LY2DUS24VDC.....	RELAY

#### NOTICE

Part number on this Suggested Spare Parts list may supersede/replace the P/N shown in the text pages of this book.

# GENERATOR ASSY.

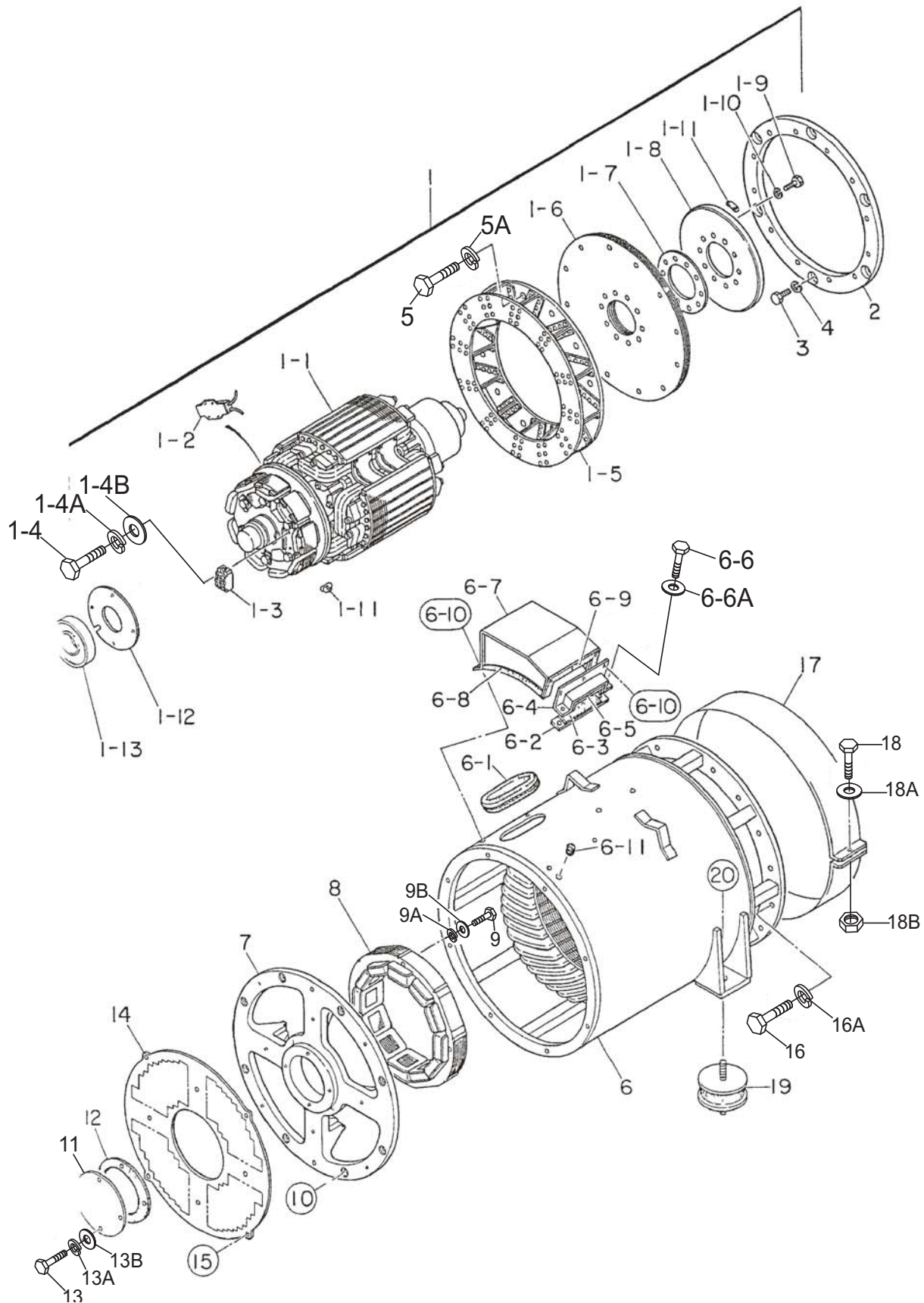



## GENERATOR ASSY.

<u>NO.</u>	<u>PART NO.</u>	<u>PART NAME</u>	<u>QTY.</u>	<u>REMARKS</u>
1	C3110000502	ROTOR ASSY.....	1.....	INCLUDES ITEMS W/*
1-1		FIELD ASSY	1	
1-2*	0601842401	RESISTOR, 80W 300 K OHM	2	
1-3*	0601823282	RECTIFIER	1	
1-4*	0018205020	HEX SOCKET HEAD CAP SCREW	2	
1-4A	0040005000	WASHER, LOCK	2	
1-4B	0041205000	WASHER, FLAT	2	
1-5*	8201070002	FAN	1	
1-6*	8201611004	COUPLING DISK	12	
1-7*	C3164200004	COUPLING HUB WASHER	1	
1-8*	8201015003	BALANCING PLATE.....	1.....	PURCHASE ITEMS 1-11 AS A SET
1-9*	0012116045	HEX HEAD BOLT	10	
1-10*	0042618000	WASHER, LOCK	10	
1-11*	0601000209	BALANCING WEIGHT KIT	1	
1-12	C3112500004	BEARING FLANGE	1	
1-13	007906315	BEARING	1	
2	C3164400103	COUPLING RING	1	
3	0010312050	HEX HEAD BOLT	8	
4	0042512000	WASHER, LOCK	8	
5	0010312040	HEX HEAD BOLT	12	
5-A	0042512000	WASHER, LOCK	12	
6	C3130100003	STATOR ASSY.	1	
6-1	0226200495	RUBBER SEAL	1	
6-2	8211323004	CLAMPER	1	
6-3	0223300172	RUBBER SEAL	1	
6-4	8211323103	CLAMPER	1	
6-5	0221200440	RUBBER SEAL	1	
6-6	0010110035	HEX HEAD BOLT	2	
6-6A	0041210000	WASHER, FLAT	2	
6-7	C3132200003	COVER	1	
6-8	0226000290	RUBBER SEAL	2	
6-9	0225000590	RUBBER SEAL	1	
6-10	0017106020	HEX HEAD BOLT	6	
6-11	0601850144	GROMMET	1	
7	C3154000002	END BRACKET	1	
8	C3138000003	FIELD ASSY. EXCITER	1	
9	0012110080	HEX HEAD BOLT	4	
9A	0042610000	WASHER, LOCK	4	
9B	0041210000	WASHER, FLAT	4	
10	0017112045	HEX HEAD BOLT	4	
11	C3154300104	BEARING COVER	1	
12	C3154300004	BEARING GASKET	1	

# GENERATOR ASSY. (CONTINUED)

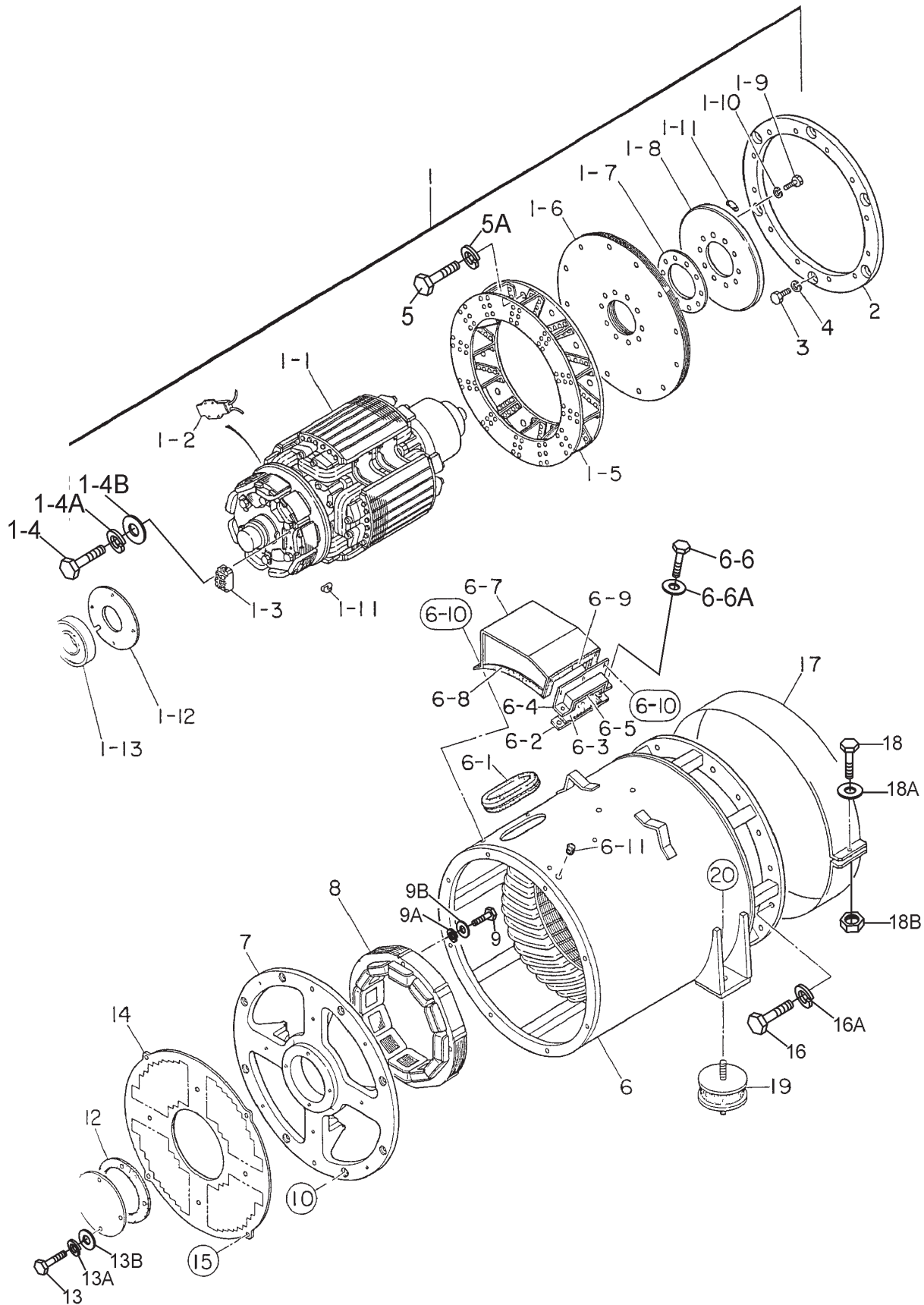

## GENERATOR ASSY. (CONTINUED)

---

<u>NO.</u>	<u>PART NO.</u>	<u>PART NAME</u>	<u>QTY.</u>	<u>REMARKS</u>
13	0010106060	HEX HEAD BOLT	4	
13A	0040006000	WASHER, LOCK	4	
13B	0041206000	WASHER, FLAT	4	
14	C3154400003	SUCTION COVER	1	
15	0017106016	HEX HEAD BOLT	8	
16	C3163600003	COUPLING ADAPTER	1	
17	0010312030	HEX HEAD BOLT	12	
17A	0042512000	WASHER, LOCK	12	
18	0070506206	BEARING	1	
19	0010312040	HEX HEAD BOLT	16	
19A	0042512000	WASHER, LOCK	16	
20	C3132300014	FAN COVER	1	
21	0010106030	HEX HEAD BOLT	1	
21A	0041206000	WASHER, FLAT	1	
21B	0601815000	NUT	1	
22	0605000061	RUBBER SUSPENSION	4	
23	0030016000	HEX NUT	8	
23A	0040016000	WASHER, LOCK	8	

# ENGINE OPERATING PANEL ASSY.

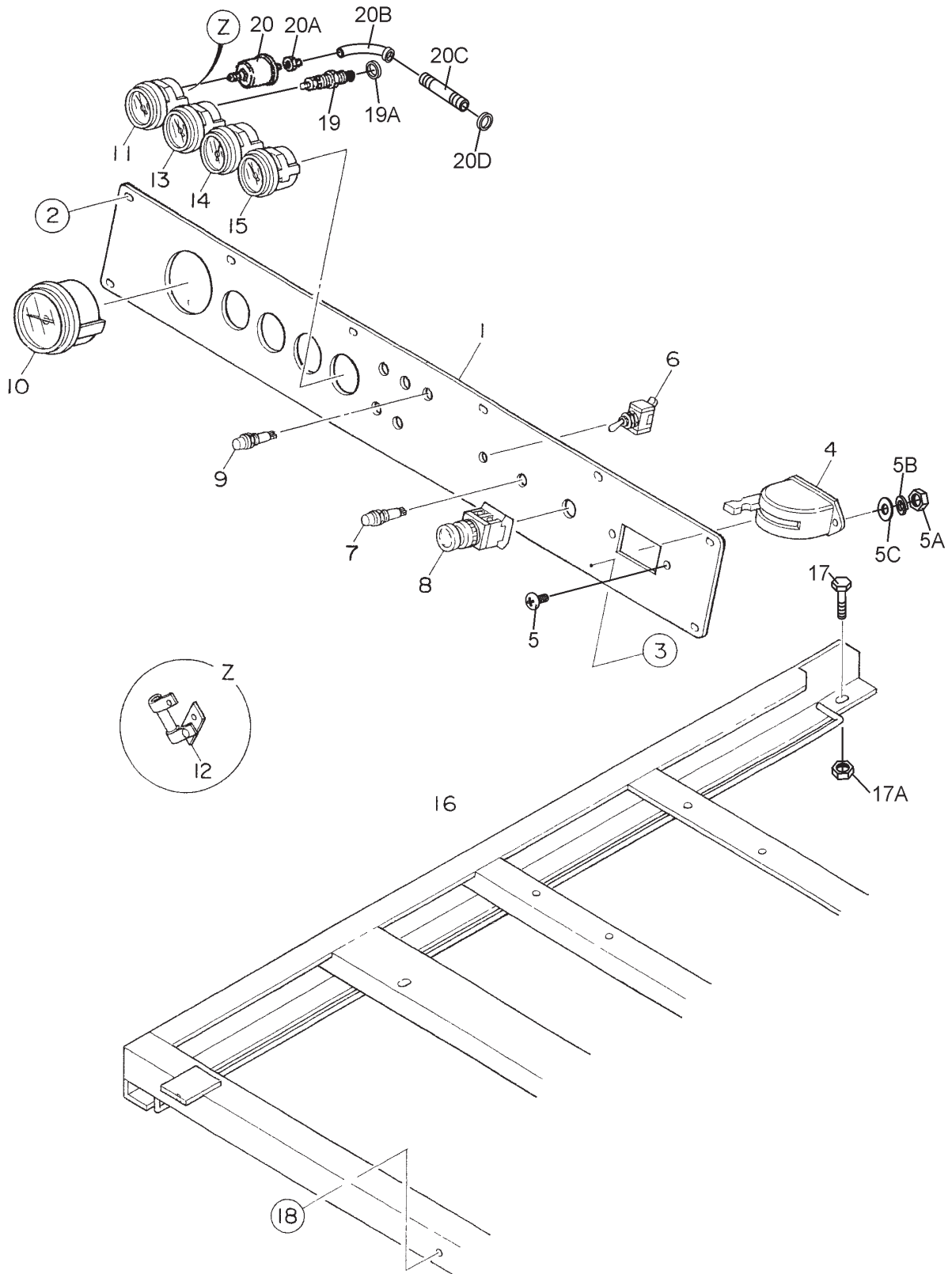

## ENGINE OPERATING PANEL ASSY.

<u>NO.</u>	<u>PART NO.</u>	<u>PART NAME</u>	<u>QTY.</u>	<u>REMARKS</u>
1	C3351100603	OPERATING PANEL	1	
2	0017106020	HEX HEAD BOLT	8	
3	0207006000	HEX NUT	4	
4	1823200010	BATTERY SWITCH .....	1	REPLACES P/N 0602101001
5	0021008080	MACHINE SCREW	2	
5A	0030008000	HEX NUT	2	
5B	0040008000	WASHER, LOCK	2	
5C	0041608000	WASHER, FLAT	2	
6	0601830710	ENGINE SPEED SWITCH	1	
7	0602103090	PREHEAT LAMP	1	
7A	0601810244	BULB, DC 28V	1	
8	0601831589	EMERGINCY STOP BUTTON	1	
9	0602103090	ALARM LAMP	5	
9A	0601810244	BULB, DC 28V	5	
10	0602120095	TACHOMETER	1	
11	0602122093	OIL PRESSURE GAUGE	1	
12	0601842450	VOLTAGE DIVIDER	1	
13	0602123092	WATER TEMPERATURE GAUGE	1	
14	0602121081	CHARGING AMMETER	1	
15	0602125091	FUEL GAUGE	1	
16	C3483003303	SET FRAME	1	
17	0017110030	HEX HEAD BOLT	2	
17A	0207010000	HEX NUT	2	
18	0017110030	HEX HEAD BOLT	3	
19	0602123267	WATER TEMPERATURE UNIT	1	
19A	0602021702	PACKING	1	
20	0602122272	OIL PRESSURE UNIT	1	
20A	M9200100004	ADAPTER OIL PRESSURE UNIT	1	
20B	0130200000	STREET ELBOW	1	
20C	8943998582	ADAPTER.....	1	REPLACES P/N 0602020220
20D	1096301410	PACKING.....	1	REPLACES P/N 0602021701

# CONTROL BOX ASSY.

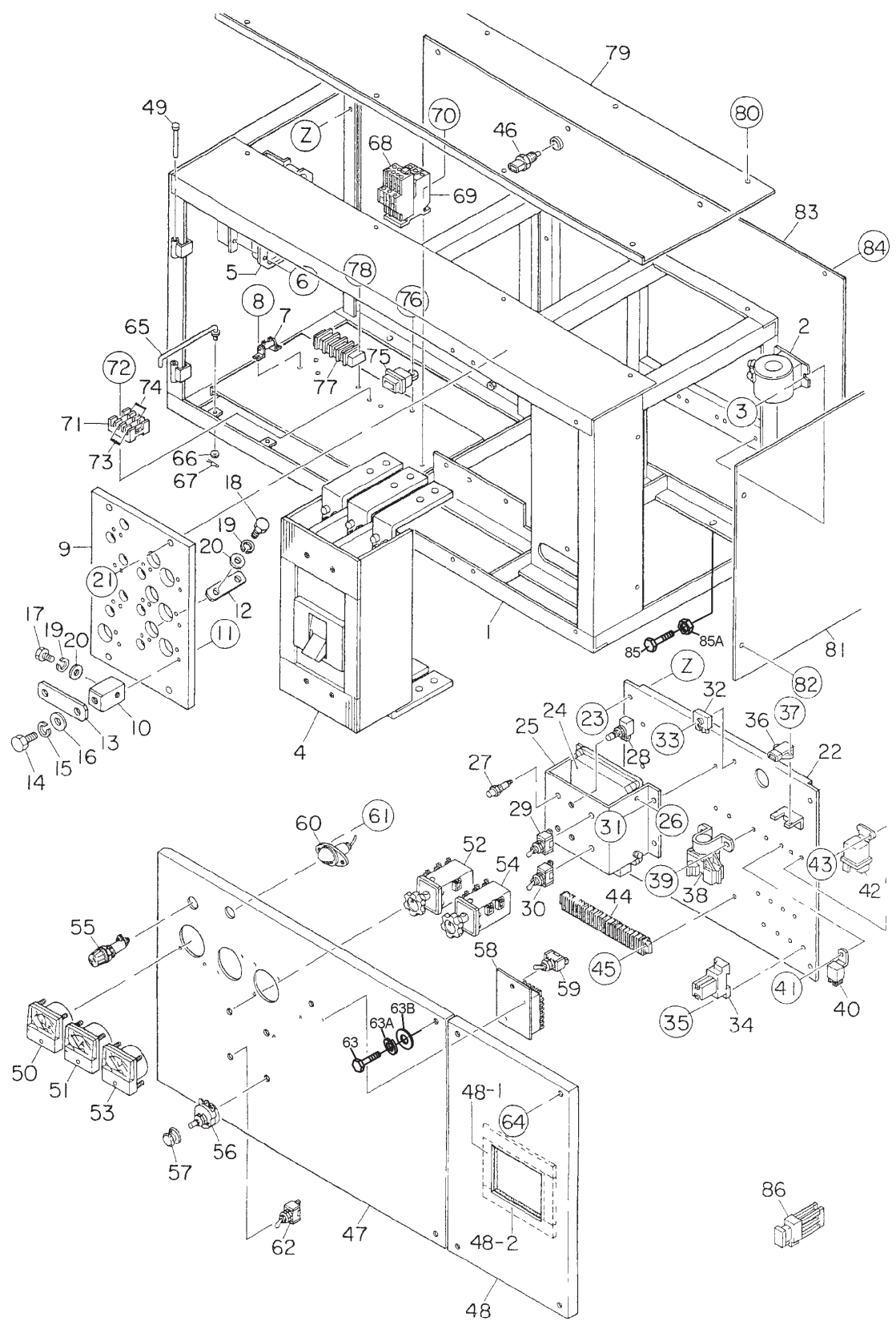

## CONTROL BOX ASSY.

<u>NO.</u>	<u>PART NO.</u>	<u>PART NAME</u>	<u>QTY.</u>	<u>REMARKS</u>
1	C3213002802	CONTROL BOX	1	
2	0601801170	CURRENT TRANSFORMER, 750/5A	3	
3	0027106016	MACHINE SCREW	6	
4	0601807514	CIRCUIT BREAKER, 1000A	1	
5	0601820625	AUTOMATIC VOLTAGE REGULATOR	1	
6	0027105016	MACHINE SCREW	4	
7	0601842468	RESISTOR, 5W 150 OHM	1	
8	0027103010	MACHINE SCREW	2	
9	C3274000003	VOLTAGE CHANGE- OVER BOARD	1	
10	8221852104	CHANGE TERMINAL	10	
11	0017108030	HEX HEAD BOLT	20	
12	C2277200004	TERMINAL PLATE	3	
13	8221853104	CHANGE PLATE	6	
14	0801830804	HEX HEAD BOLT	10	
15	0040016000	WASHER, LOCK	10	
16	0041416000	WASHER, FLAT	10	
17	0801830704	HEX HEAD BOLT	13	
18	8201852504	HEX HEAD BOLT	3	
19	0040012000	WASHER, LOCK	16	
20	0041412000	WASHER, FLAT	16	
21	0017110030	HEX HEAD BOLT	4	
22	C3260503003	ELECTRIC PARTS SET PANEL	1	
23	0017108020	HEX HEAD BOLT	4	
24	8980956110	CONTROLLER.....	1	REPLACES P/N 0602202684
25	C3260503104	BRACKET	1	
26	0016906012	HEX HEAD BOLT	4	
27	0602103090	DIAGNOSTIC LAMP	1	
27A	0601810244	BULB, DC28V	1	
28	0601831205	DIAGNOSTIC BUTTON	1	
29	0601830710	DIAGNOSTIC SWITCH	1	
30	0601830746	HIGH IDLE SPEED SWITCH	1	
31	0016906016	HEX HEAD BOLT	4	
32	0601823240	RECTIFIER	1	
33	0027105020	MACHINE SCREW	1	
34	LY2DUS24VDC	RELAY .....	4	REPLACES P/N 0601827655
34A	PTF08A	SOCKET.....	4	REPLACES P/N 0601823109
34B	PYCA1	HOLDER .....	4	REPLACES P/N 0601824400
35	0027104020	MACHINE SCREW	8	
36	8972177780	BAROMETRIC PRESSURE SENSOR .....	1	REPLACES P/N 0602130220
37	0027104010	MACHINE SCREW	2	
38	8980056310	STARTER RELAY .....	1	REPLACES P/N 0602201401
39	0016906016	HEX HEAD BOLT	2	
40	8980137900	RELAY .....	2	REPLACES P/N 0602202682
41	0027105010	MACHINE SCREW	2	





## CONTROL BOX ASSY. (CONTINUED)

<u>NO.</u>	<u>PART NO.</u>	<u>PART NAME</u>	<u>QTY.</u>	<u>REMARKS</u>
42	8944607060	GLOW PLUG RELAY .....	1	REPLACES P/N 0602202683
43	0027105010	MACHINE SCREW	2	
44	0601815154	TERMINAL BLOCK	1	
45	0027104016	MACHINE SCREW	2	
46	8121468300	INLET AIR TEMPERATURE SENSOR .....	1	REPLACES P/N 0603210240
47	C3224001303	CONTROL PANEL	1	
48	C3224002403	CONTROL PANEL	1	
48-1	0228800115	RUBBER SEAL	2	
48-2	0228800190	RUBBER SEAL	2	
49	0605011211	PIN	2	
50	0601807622	FREQUENCY METER, 45~65Hz 200V	1	
51	0601806987	AC AMMETER, 0~750A 0~1500A	1	
52	0601801040	AMMETER CHANGE- OVER SWITCH	1	
53	0601806887	AC VOLTMETER, 0~600V	1	
54	0601801041	VOLTMETER CHANGE- OVER SWITCH	1	
55	0601810072	PILOT LAMP	1	
55A	0601810261	BULB, 13W	1	
56	0601840073	RHEOSTAT, VOLT. REG, 2W 1K OHM	1	
57	0601840121	KNOB	1	
58	ECU9988N220V	ENGINE CONTROLLER, .....	1	REPLACES P/N 0602202545
59	0601830765	SWITCH	1	
60	0601810161	PANEL LIGHT	1	
60A	0601810214	BULB	1	
61	0207004000	HEX NUT	2	
62	0601830710	PANEL LIGHT SWITCH	1	
63	C9221100004	HEX HEAD BOLT	2	
63A	0040008000	WASHER, LOCK	2	
63B	0041208000	WASHER, FLAT	2	
63C	0080200007	SNAP RING	2	
64	0017108040	HEX HEAD BOLT	4	
65	3871824004	CONTROL PANEL STOPPER	1	
66	0041206000	WASHER, FLAT	1	
67	0605010502	SNAP PIN	1	
68	0601820847	OVER CURRENT RELAY	1	
69	0601820848	OVER CURRENT RELAY	1	
70	0027104016	MACHINE SCREW	2	
71	0601802204	FUSE HOLDER	1	
72	0601806671	FUSE, 15A	2	
73	0601802149	FUSE, 10A	2	
74	0027103020	MACHINE SCREW	2	
75	C3358201704	FUSE HOLDER ASSY.	1	
75A	0601806644	FUSE, 30A	1	
75B	0601802410	FUSE HOLDER BRACKET	1	
76	0017106016	HEX HEAD BOLT	1	
77	0601815153	TERMINAL BLOCK	1	

# CONTROL BOX ASSY. (CONTINUED)

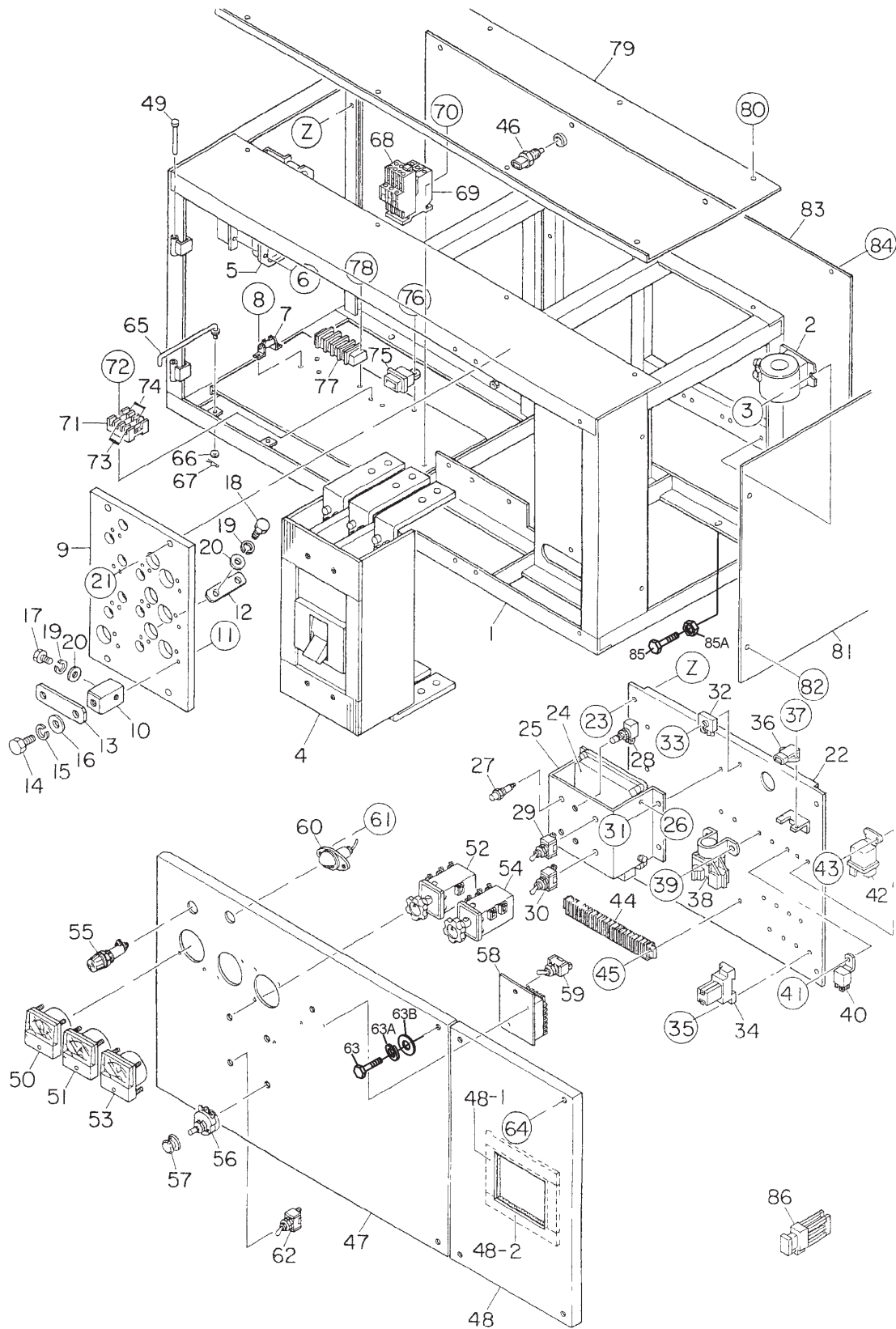

## **CONTROL BOX ASSY. (CONTINUED)**

---

<u>NO.</u>	<u>PART NO.</u>	<u>PART NAME</u>	<u>QTY.</u>	<u>REMARKS</u>
78	0027104020	MACHINE SCREW	2	
79	8221814804	CONTROL BOX COVER	1	
80	0017108020	HEX HEAD BOLT	8	
81	8224117004	CONTROL BOX SIDE PANEL	1	
82	0017108020	HEX HEAD BOLT	4	
83	C3213400604	CONTROL BOX PANEL	1	
84	0017108020	HEX HEAD BOLT	8	
85	0017110035	HEX HEAD BOLT	4	
85A	0207010000	HEX NUT	4	
86	0601806640	FUSE, 65A	1	



## ENGINE AND RADIATOR ASSY.

<u>NO.</u>	<u>PART NO.</u>	<u>PART NAME</u>	<u>QTY.</u>	<u>REMARKS</u>
1	C3923200194	ENGINE, ISUZU 6WG1X	1	
1-1	1132402330	MAIN OIL FILTER CARTRIDGE .....	1	REPLACES P/N 0602041219
1-2	1132402410	BYPASS OIL FILTER CARTRIDGE .....	1	REPLACES P/N 0602041220
1-3	8980088400	MAIN FUEL FILTER ELEMENT .....	2	REPLACES P/N 0602042515
2	C3303200504	ENGINE FOOT	2	
3	0010314040	HEX HEAD BOLT	8	
4	0040014000	WASHER, LOCK	8	
5	0041614000	WASHER, FLAT	8	
6	C3303200604	ENGINE FOOT	1	
7	C3303200704	ENGINE FOOT	1	
8	0010316040	HEX HEAD BOLT	8	
9	0040016000	WASHER, LOCK	8	
10	0041616000	WASHER, FLAT	8	
11	0605000061	RUBBER SUSPENSION	4	
12	0030016000	HEX NUT	8	
13	0040016000	WASHER, LOCK	8	
14	0041616000	WASHER, FLAT	8	
15	C3923200174	RADIATOR & INTER COOLER ASSY.	1	
15-1	0602011059	CAP	2	
16	C3493600004	ACOUSTIC SHEET	1	
17	0010116065	HEX HEAD BOLT	6	
18	0030016000	HEX NUT	6	
19	0040016000	WASHER, LOCK	6	
20	0041216000	WASHER, FLAT	12	
21	C3311100504	RADIATOR BRACKET	1	
22	C3311100604	RADIATOR BRACKET	1	
23	0017112025	HEX HEAD BOLT	4	
24	0017112025	HEX HEAD BOLT	2	
25	C33110200403	FAN GUARD	1	
26	C3310200503	FAN GUARD	1	
27	0016910025	HEX HEAD BOLT	16	
28	C3310500003	RADIATOR HOSE	1	
29	C3310500103	RADIATOR HOSE	1	
30	C3310400004	RADIATOR PIPE	1	
31	C3310500404	RADIATOR HOSE	2	
32	0605515290	HOSE BAND	14	
33	0602123290	COOLANT LEVEL SWITCH	1	
34	C3310500203	INTER COOLER HOSE	1	
35	0605515214	HOSE BAND	1	
36	0605515213	HOSE BAND	1	
37	C3310500303	INTER COOLER HOSE	1	
38	0605515238	HOSE BAND	1	
39	0605515239	HOSE BAND	1	
40	0602046539	AIR CLEANER	1	
40A	0602046628	AIR CLEANER OUTER ELEMENT	1	
40B	0602046629	AIR CLEANER INNER ELEMENT	1	

# ENGINE AND RADIATOR ASSY. (CONTINUED)

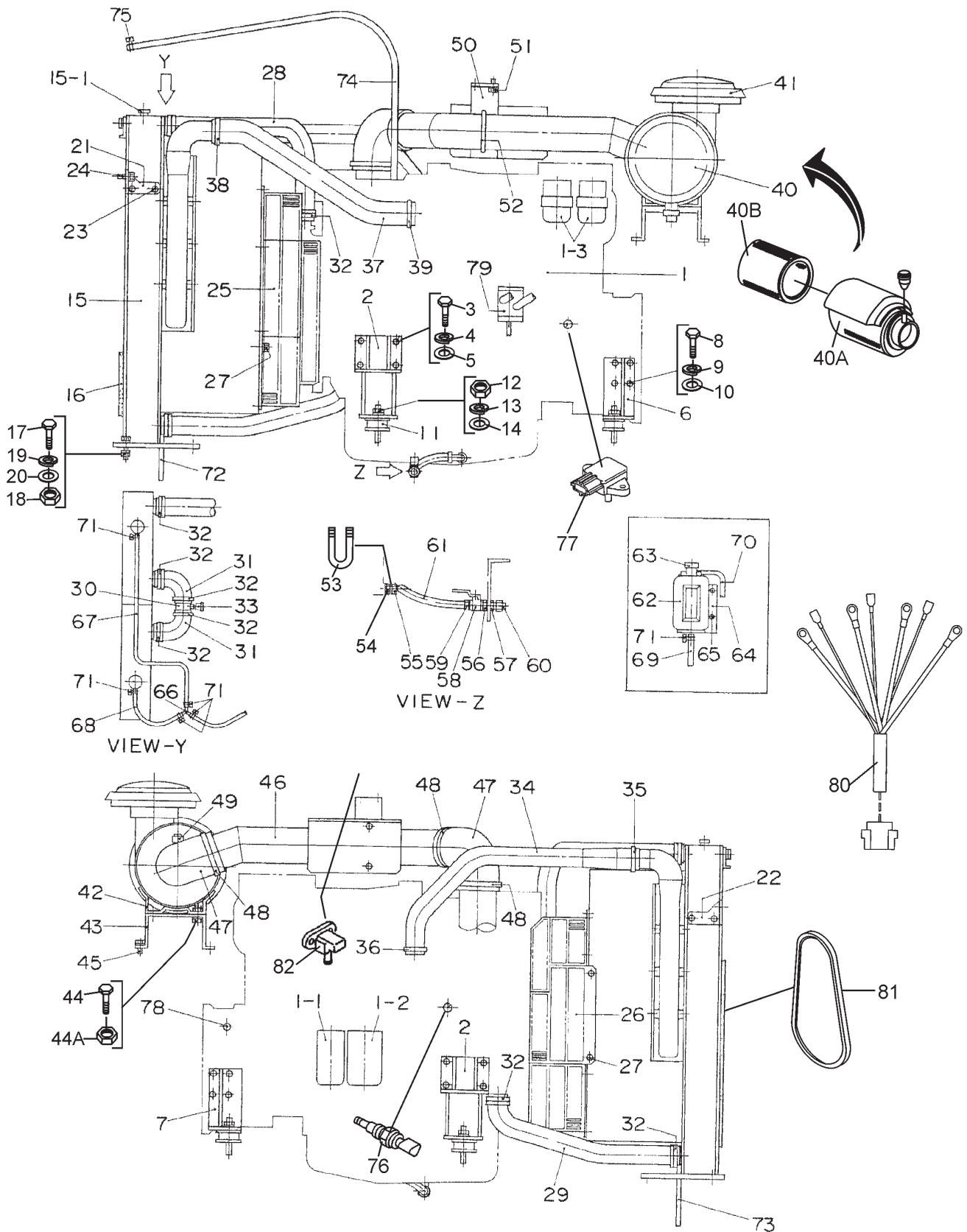

## ENGINE AND RADIATOR ASSY. (CONTINUED)

<u>NO.</u>	<u>PART NO.</u>	<u>PART NAME</u>	<u>QTY.</u>	<u>REMARKS</u>
41	0602040779	AIR CLEANER CAP	1	
42	0602040582	AIR CLEANER BAND	2	
43	C3373200004	AIR CLEANER BRACKET	1	
44	0016910025	HEX HEAD BOLT	4	
44A	0207010000	HEX NUT	4	
45	0016910025	HEX HEAD BOLT	4	
46	C3373000003	AIR CLEANER PIPE	1	
47	0602040393	90 DEGREE ELBOW	2	
48	0605515260	HOSE BAND	4	
49	0602040666	AIR CLEANER INDICATOR	1	
50	C3373200104	AIR CLEANER PIPE BRACKET	1	
51	0016908020	HEX HEAD BOLT	4	
52	0602326064	U BOLT	1	
53	0602022560	ADAPTER	1	
54	M1320300304	PACKING	1	
55	0602022561	90 DEGREE ELBOW	1	
56	0603306590	CONNECTOR	1	
57	0603300285	ROCKNUT	1	
58	0605511395	VALVE	1	
59	0603306395	HOSE JOINT	1	
60	0602021070	CAP	1	
61	0269200500	DRAIN HOSE	1	
62	0802081003	RESERVE TANK	1	
63	0602010900	RESERVE TANK CAP	1	
64	C1317100103	RESERVE TANK BRACKET	1	
65	0016910025	HEX HEAD BOLT	2	
66	0602022929	JOINT	1	
67	0199900800	HOSE	1	
68	0199900300	HOSE	1	
69	0199901600	HOSE	1	
70	0193602000	HOSE	1	
71	0605515106	HOSE BAND	6	
72	0193601300	HOSE	1	
73	0193600550	HOSE	1	
74	0269502100	HOSE	1	
75	0605515067	HOSE BAND	2	
76	8973639360	WATER TEMPERATURE SENSOR	1	
77	8972177780	OIL PRESSURE SENSOR	1	
78	0602120465	PICK UP TACHOMETER	1	
79	8980305320	BLOWBY FILTER ELEMENT.....	1.....	REPLACES P/N 0602044210
80	C3357200002	ENGINE WIRE HARNESS	1	
81	1136714740	FAN BELT.....	3.....	REPLACES P/N 0602015252
82	1802200140	BOOST SENSOR	1	

# OUTPUT TERMINAL ASSY.

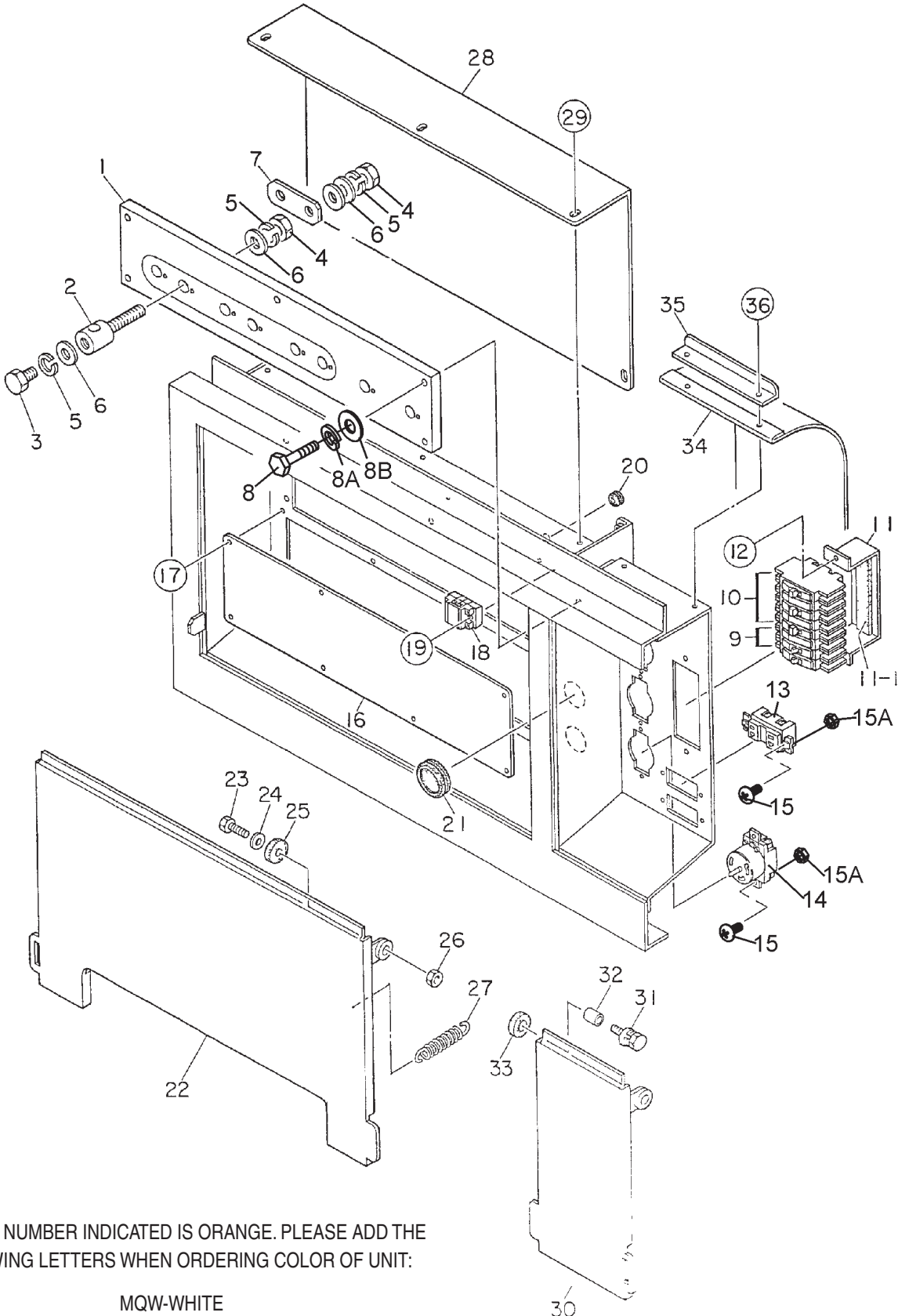

THE PART NUMBER INDICATED IS ORANGE. PLEASE ADD THE FOLLOWING LETTERS WHEN ORDERING COLOR OF UNIT:

MQW-WHITE

THE SERIAL NUMBER MAY BE REQUIRED.



## OUTPUT TERMINAL ASSY.

<u>NO.</u>	<u>PART NO.</u>	<u>PART NAME</u>	<u>QTY.</u>	<u>REMARKS</u>
1	C2231700403	OUTPUT TERMINAL SET BOARD	1	
2	C0277500004	OUTPUT TERMINAL	8	
3	0801830904	HEX HEAD BOLT	8	
4	0039320000	HEX NUT	16	
5	0040020000	WASHER, LOCK	24	
6	0041420000	WASHER, FLAT	32	
7	3501860604	TERMINAL PLATE	3	
8	0019110050	HEX HEAD BOLT	5	
8A	0042310000	WASHER, LOCK	5	
8B	0042410000	WASHER, FLAT	5	
9	0601808803	CIRCUIT BREAKER, 20A	2	
10	0601808804	CIRCUIT BREAKER, 50A	3	
11	C3261600704	CIRCUIT BREAKER BREAKER	1	
11-1	0221200150	RUBBER CUSHION	1	
12	0019206016	HEX HEAD BOLT	2	
13	0601812598	RECEPTACLE, GF-530EM	2	
14	0601812565	RECEPTACLE, CS-6369	3	
15	0025304016	MACHINE SCREW	10	
15A	0207004000	HEX NUT	10	
16	C2234500104	COVER	1	
17	0019206016	HEX HEAD BOLT	8	
18	0601815194	TERMINAL BLOCK	1	
19	0025304016	MACHINE SCREW	2	
20	0601850275	GROMMET	1	
21	0601851780	GROMMET	2	
22	C2237102303	OUTPUT TERMINAL COVER	1	
23	0019112045	HEX HEAD BOLT	2	
24	0042412000	WASHER, FLAT	4	
25	0805015604	STAY RUBBER	2	
26	0205012000	HEX NUT	2	
27	0845043704	SPRING	2	
28	C2237101204	COVER	1	
29	0019208020	HEX HEAD BOLT	7	
30	C2237102403	OUTPUT TERMINAL COVER	1	
31	0019210030	HEX HEAD BOLT	2	
32	0845054204	COLLAR	1	
33	0805015604	STAY RUBBER	1	
34	C2237101504	COVER	1	
35	C2237400104	BRACKET	1	
36	0019206020	HEX HEAD BOLT	2	

# BATTERY ASSY.

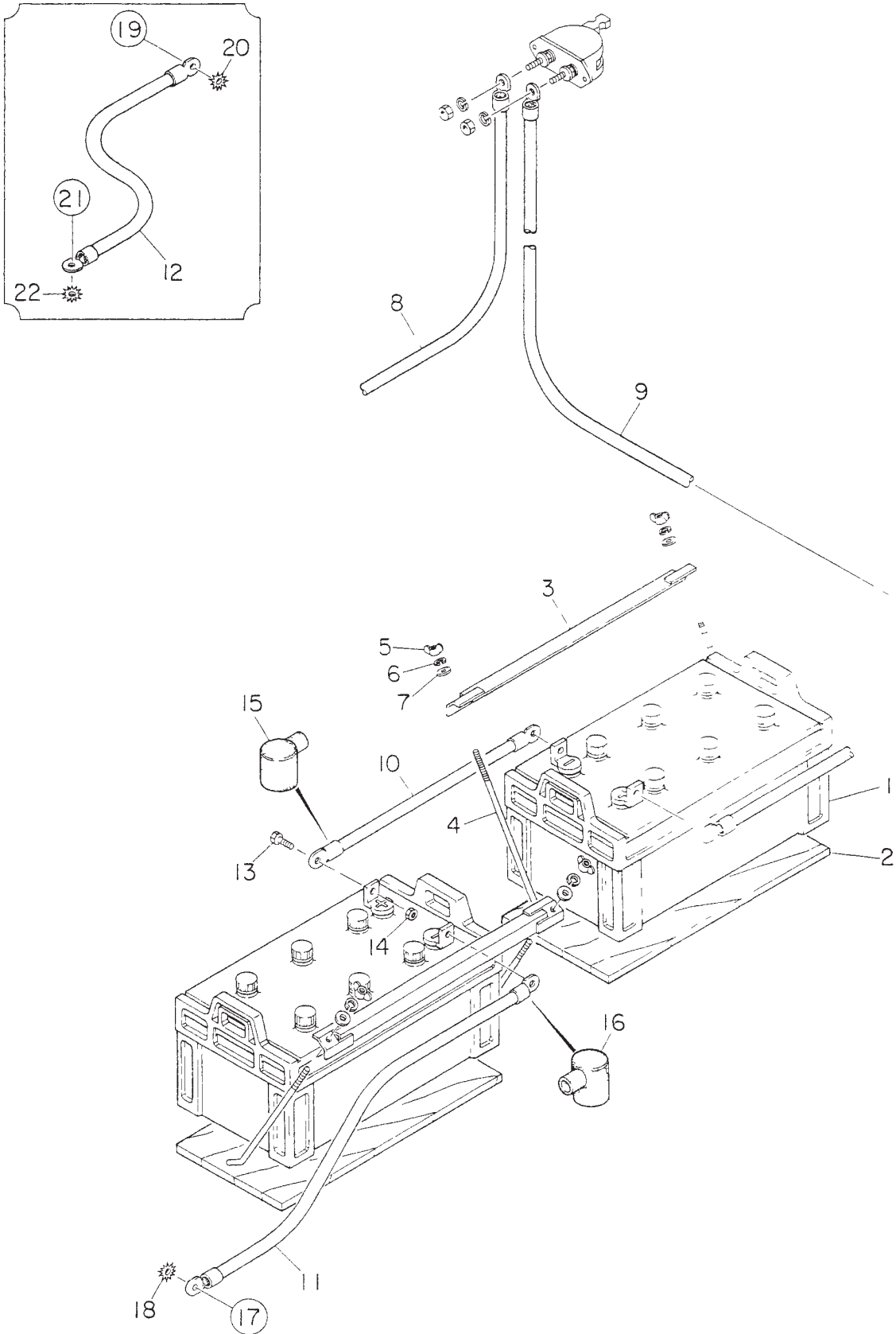

## BATTERY ASSY.

---

<u>NO.</u>	<u>PART NO.</u>	<u>PART NAME</u>	<u>QTY.</u>	<u>REMARKS</u>
1	0165721052	BATTERY	2	
2	C9109100704	BATTERY SHEET	2	
3	0805007804	BATTERY BAND	2	
4	0805006504	BATTERY BOLT	4	
5	0037808000	WING NUT	4	
6	0040008000	WASHER, LOCK	4	
7	0041608000	WASHER, FLAT	4	
8	C3346601804	BATTERY CABLE	1	
9	C3346601904	BATTERY CABLE	1	
10	C3346602004	BATTERY CABLE	1	
11	C3346602104	BATTERY CABLE	1	
12	C3346200004	EARTH CABLE	1	
13	0347010030	HEX HEAD BOLT	4	
14	0208110000	HEX NUT	4	
15	0845040114	TERMINAL CAP (+)	2	
16	0845041004	TERMINAL CAP (-)	2	
17	0017114025	HEX HEAD BOLT	1	
18	0040514000	TOOTHED WASHER	1	
19	0017110025	HEX HEAD BOLT	1	
20	0040510000	TOOTHED WASHER	1	
21	0017112025	HEX HEAD BOLT	1	
22	0040512000	TOOTHED WASHER	1	

# MUFFLER ASSY.

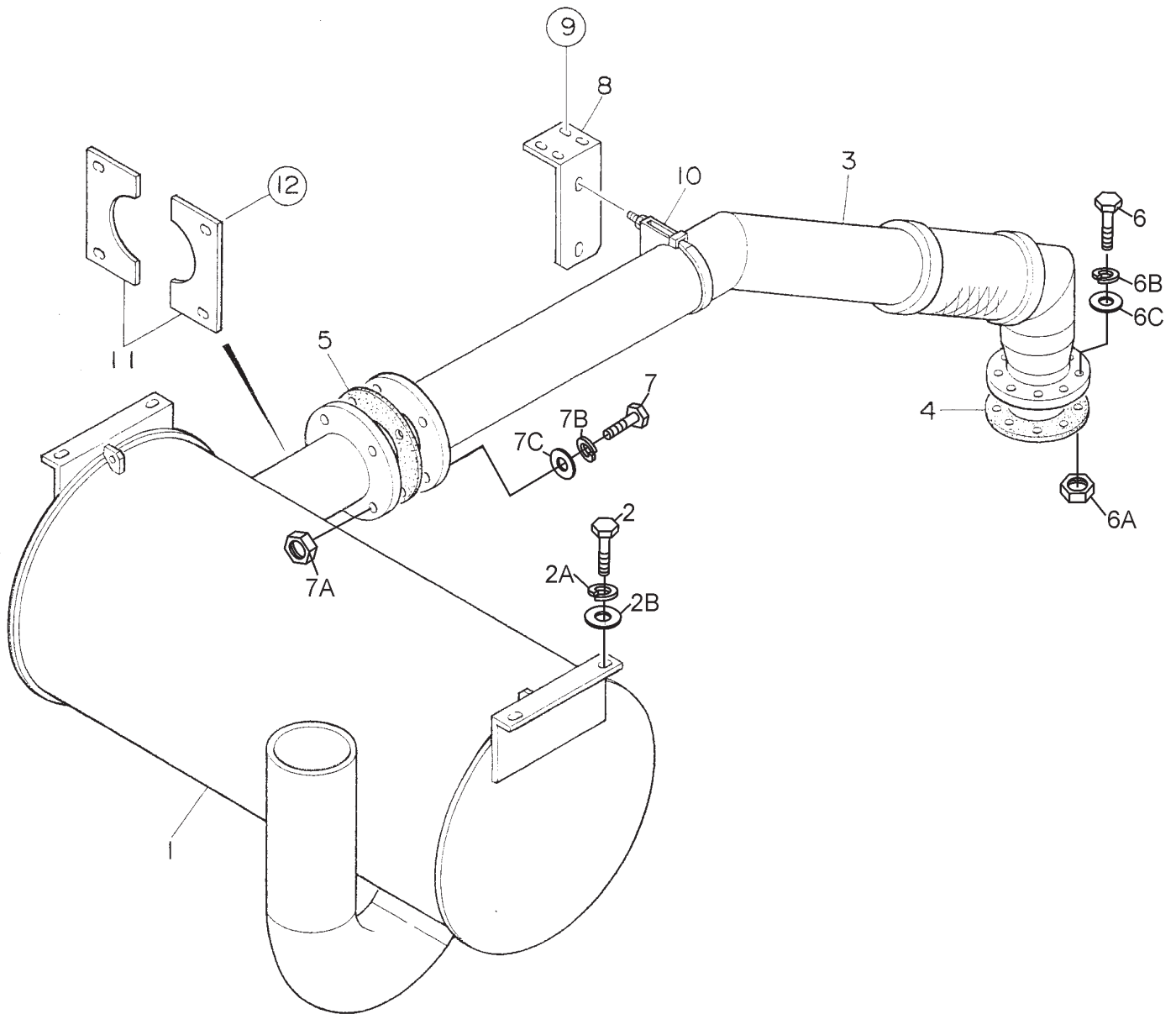

## MUFFLER ASSY.

---

<u>NO.</u>	<u>PART NO.</u>	<u>PART NAME</u>	<u>QTY.</u>	<u>REMARKS</u>
1	C3330100402	MUFFLER	1	
2	0019110025	HEX HEAD BOLT	4	
2A	0042310000	WASHER, LOCK	4	
2B	0047010030	WASHER, FLAT	4	
3	C3333001903	EXHAUST PIPE	1	
4	C9304000304	GASKET	1	
5	C3334200804	GASKET	1	
6	0010316060	HEX HEAD BOLT	8	
6A	0030316000	HEX NUT	8	
6B	0042516000	WASHER, LOCK	8	
6C	0041616000	WASHER, FLAT	16	
7	0010316060	HEX HEAD BOLT	4	
7A	0030016000	HEX NUT	4	
7B	0042516000	WASHER, LOCK	4	
7C	0041616000	WASHER, FLAT	8	
8	C3333302104	BRACKET	1	
9	0017108020	HEX HEAD BOLT	4	
10	0602326065	U- BOLT	1	
11	C3331300404	COVER	2	
12	0019208020	HEX HEAD BOLT	4	

# FUEL TANK ASSY. (S/N 3813334 AND BELOW)

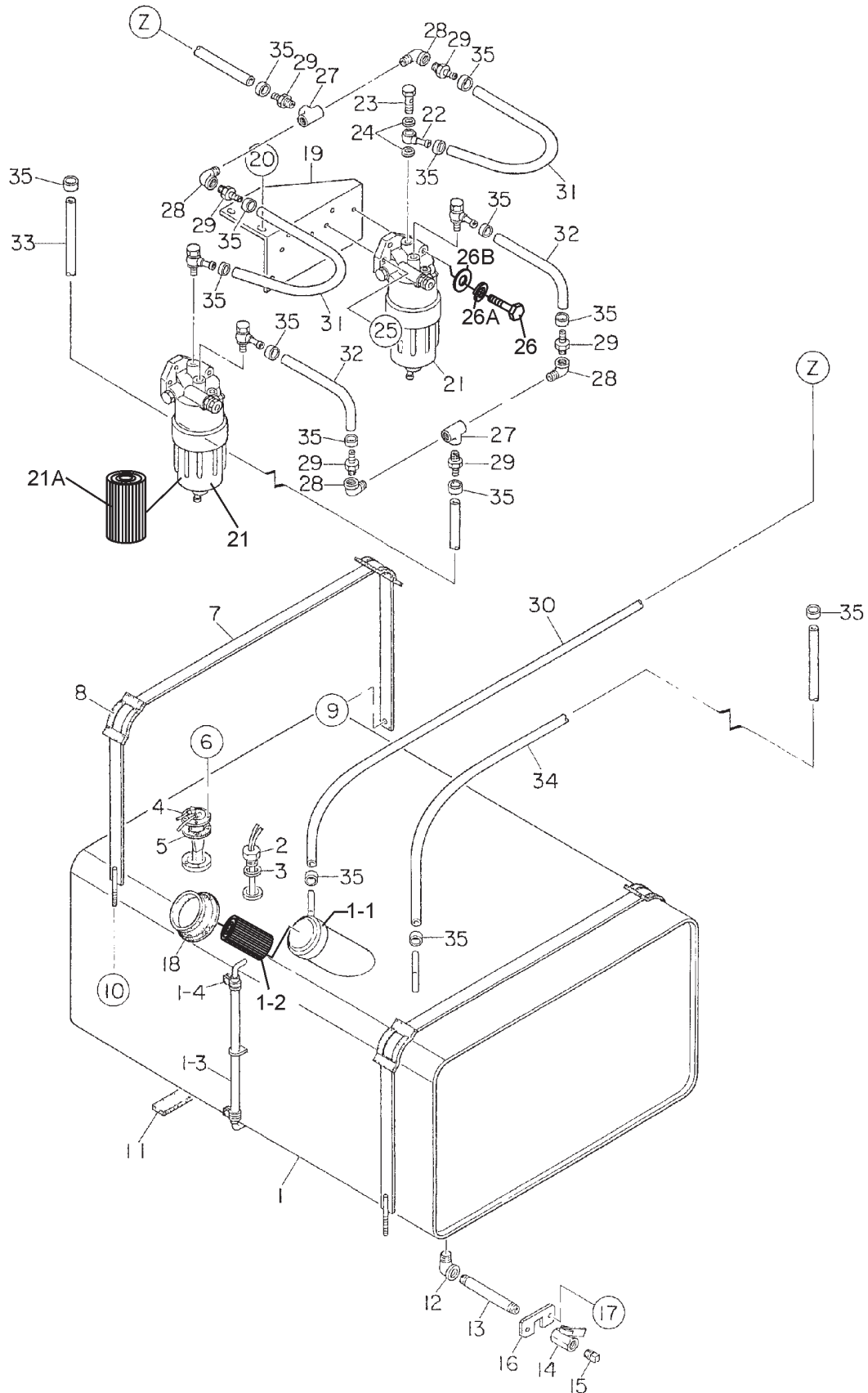

## FUEL TANK ASSY. (S/N 3813334 AND BELOW)

<u>NO.</u>	<u>PART NO.</u>	<u>PART NAME</u>	<u>QTY.</u>	<u>REMARKS</u>
1	C3363002503	FUEL TANK	1	
1-1	0845500104	FUEL TANK CAP	1	
1-2	0810105400	FUEL FILTER	1	
1-3	0264100525	FUEL GAUGE HOSE	1	
1-4	0605515079	HOSE BAND	2	
2	0605503020	FUEL SENSOR	1	
3	0802120604	PACKING	1	
4	0605501089	FUEL UNIT	1	
5	0605516090	PACKING	1	
6	0022905015	MACHINE SCREW	5	
7	8225523104	TANK BAND	2	
8	0805003414	TANK BAND PAD	4	
9	0016908020	HEX HEAD BOLT	2	
10	0207308000	SUPER LOCK NUT	2	
11	0222100300	TANK SHEET	6	
12	0130206000	STREET ELBOW, 1/2"	1	
13	0134306170	DRAIN PIPE	1	
14	0603325026	VALVE	1	
15	0132006000	PLUG, 1/2"	1	
16	C1367700304	LOCK PLATE	1	
17	0019208020	HEX HEAD BOLT	2	
18	0845039604	RUBBER SEAL	1	
19	C3366704704	BRACKET	1	
20	0016910025	HEX HEAD BOLT	3	
21	8980758550	PRIMARY FUEL FILTER ASSY.....	2.....	REPLACES P/N 0602042405
21A	8980758540	PRIMARY FUEL FILTER ELEMENT .....	2.....	REPLACES P/N 0602042516
22	8980955010	JOINT PIPE.....	4.....	REPLACES P/N 0602042662
23	1096750951	JOINT BOLT .....	4.....	REPLACES P/N 0602042621
24	1096301110	PACKING.....	8.....	REPLACES P/N 0602021702
25	0017110040	HEX HEAD BOLT	4	
26	0010110075	HEX HEAD BOLT	2	
26A	0040010000	WASHER, LOCK	2	
26B	0041210000	WASHER, FLAT	2	
27	0130406000	T-JOINT, 1/2"	2	
28	0130206000	STREET ELBOW, 1/2"	4	
29	0602022209	HOSE JOINT	6	
30	0191402500	SUCTION HOSE	1	
31	0191400600	SUCTION HOSE	2	
32	0191400500	SUCTION HOSE	2	
33	0191402800	SUCTION HOSE	1	
34	0191405300	RETURN HOSE	1	
35	0605515132	HOSE BAND	14	

# FUEL TANK ASSY. (S/N 3813335 AND ABOVE)

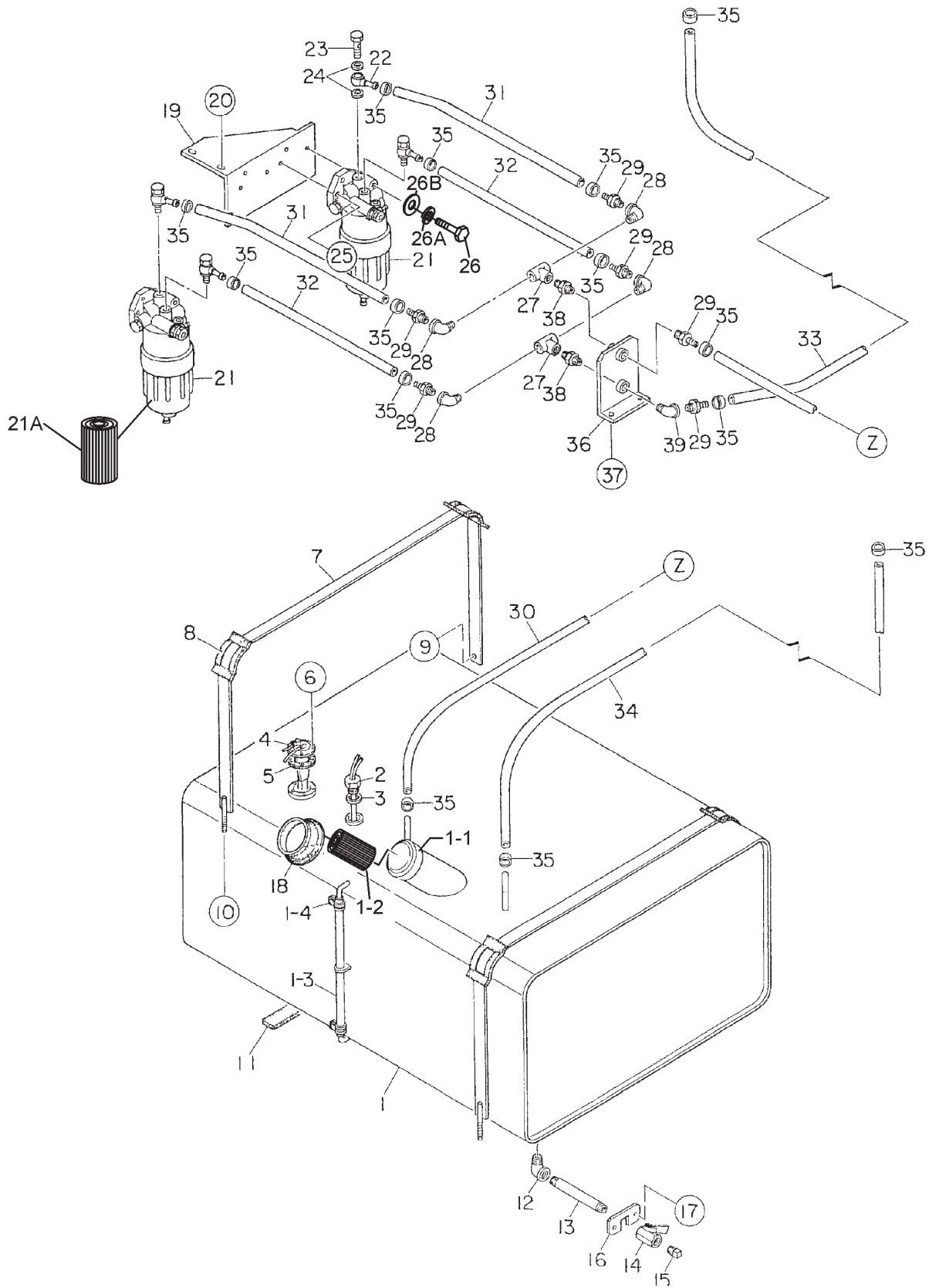



## FUEL TANK ASSY. (S/N 3813335 AND ABOVE)

<u>NO.</u>	<u>PART NO.</u>	<u>PART NAME</u>	<u>QTY.</u>	<u>REMARKS</u>
1	C3363002503	FUEL TANK	1	
1-1	0845500104	FUEL TANK CAP	1	
1-2	0810105400	FUEL FILTER	1	
1-3	0264100525	FUEL GAUGE HOSE	1	
1-4	0605515079	HOSE BAND	2	
2	0605503020	FUEL SENSOR	1	
3	0802120604	PACKING	1	
4	0605501089	FUEL UNIT	1	
5	0605516090	PACKING	1	
6	0022905015	MACHINE SCREW	5	
7	8225523104	TANK BAND	2	
8	0805003414	TANK BAND PAD	4	
9	0016908020	HEX HEAD BOLT	2	
10	0207308000	SUPER LOCK NUT	2	
11	0222100300	TANK SHEET	6	
12	0130206000	STREET ELBOW, 1/2"	1	
13	0134306170	DRAIN PIPE	1	
14	0603325026	VALVE	1	
15	0132006000	PLUG, 1/2"	1	
16	C1367700304	LOCK PLATE	1	
17	0019208020	HEX HEAD BOLT	2	
18	0845039604	RUBBER SEAL	1	
19	C3366704704	BRACKET	1	
20	0016910025	HEX HEAD BOLT	3	
21	8980758550	PRIMARY FUEL FILTER ASSY.....	2.....	REPLACES P/N 0602042405
21A	8980758540	PRIMARY FUEL FILTER ELEMENT .....	2.....	REPLACES P/N 0602042516
22	8980955010	JOINT PIPE.....	4.....	REPLACES P/N 0602042662
23	1096750951	JOINT BOLT .....	4.....	REPLACES P/N 0602042621
24	1096301110	PAACKING .....	8.....	REPLACES P/N 0602021702
25	0017110040	HEX HEAD BOLT	4	
26	0010110075	HEX HEAD BOLT	2	
26A	0040010000	WASHER, LOCK	2	
26B	0041210000	WASHER, FLAT	2	
27	0130406000	T-JOINT 1/2"	2	
28	0130206000	STREET ELBOW, 1/2"	4	
29	0602022209	HOSE JOINT	6	
30	0191402500	SUCTION HOSE	1	
31	0191400600	SUCTION HOSE	2	
32	0191400500	SUCTION HOSE	2	
33	0191402800	SUCTION HOSE	1	
34	0191405300	RETURN HOSE	1	
35	0605515132	HOSE BAND	14	
36	C3366704804	BRACKET .....	1.....	S/N 3813335 AND ABOVE
37	0019208020	HEX HEAD BOLT .....	2.....	S/N 3813335 AND ABOVE
38	0131506000	NIPPLE 1/2" .....	2.....	S/N 3813335 AND ABOVE
39	0130206000	STREET ELBOW 1/2" .....	2.....	S/N 3813335 AND ABOVE

# ENCLOSURE #1 ASSY.

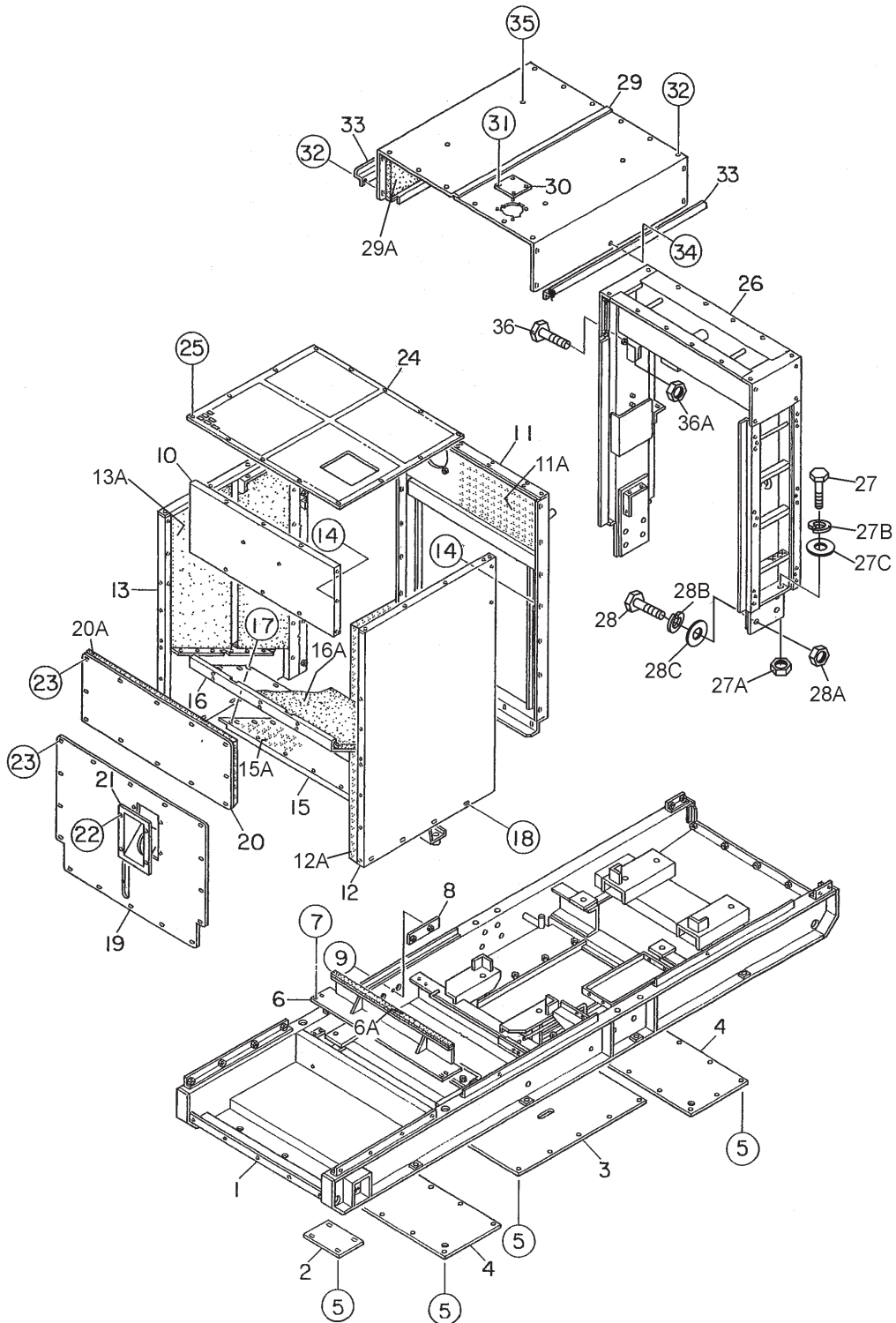

THE PART NUMBER INDICATED IS ORANGE. PLEASE ADD THE FOLLOWING LETTERS WHEN ORDERING COLOR OF UNIT:

MQW-WHITE

THE SERIAL NUMBER MAY BE REQUIRED.

**ENCLOSURE #1 ASSY.**

<u>NO.</u>	<u>PART NO.</u>	<u>PART NAME</u>	<u>QTY.</u>	<u>REMARKS</u>
1	C3413003502	BASE	1	
2	C3414100104	FLOOR PANEL	1	
3	C3413100304	FLOOR PANEL	1	
4	C3414100804	FLOOR PANEL	2	
5	0019208020	HEX HEAD BOLT	38	
6	C3413600004	BASE DUCT	1	
6A	0228901070	RUBBER SEAL	1	
7	0019208020	HEX HEAD BOLT	4	
8	C2367700404	COVER	1	
9	0019208025	HEX HEAD BOLT	2	
10	C3424001204	FRONT FRAME	1	
10A	C3493100703	LINING	1	
11	C3423001003	FRONT FRAME	1	
11A	C3493100703	LINING	1	
12	C3423001102	FRONT FRAME	1	
12A	C3493100703	LINING	1	
13	C3423001202	FRONT FRAME	1	
13A	C3493100703	LINING	1	
14	0019208020	HEX HEAD BOLT	20	
15	C3423300003	AIR GUIDE PANEL	1	
15A	C3492100703	LINING	1	
16	C3424301103	AIR GUIDE PANEL	1	
16A	C3493100703	LINING	1	
17	0019208020	HEX HEAD BOLT	24	
18	0019210025	HEX HEAD BOLT	8	
19	C3424201403	FRONT FRAME COVER	1	
20	C3424203104	FRONT FRAME COVER	1	
20A	C3494102604	LINING	1	
21	0845042703	FILLER BASKET	1	
22	0019208020	HEX HEAD BOLT	4	
23	0019208020	HEX HEAD BOLT	28	
24	C3423201103	FRONT FRAME COVER	1	
25	0019208020	HEX HEAD BOLT	14	
26	C3433000202	CENTER FRAME	1	
27	0010120060	HEX HEAD BOLT	4	
27A	0030020000	HEX NUT	4	
27B	0040020000	WASHER, LOCK	4	
27C	0041620000	WASHER, FLAT	8	
28	0010120050	HEX HEAD BOLT	8	
28A	0030020000	HEX NUT	8	
28C	0041620000	WASHER, FLAT	16	
29	C3463101402	ROOF PANEL	1	
29A	C3493500203	LINING	1	
30	M3310600004	COVER	1	
31	0019204020	HEX HEAD BOLT	4	
32	0019208020	HEX HEAD BOLT	20	
33	C3463500204	GUTTER	2	
34	0019208020	HEX HEAD BOLT	2	
35	0019210025	HEX HEAD BOLT	4	
36	0019116025	HEX HEAD BOLT	1	
36A	0042416000	HEX NUT	1	

# ENCLOSURE #2 ASSY.

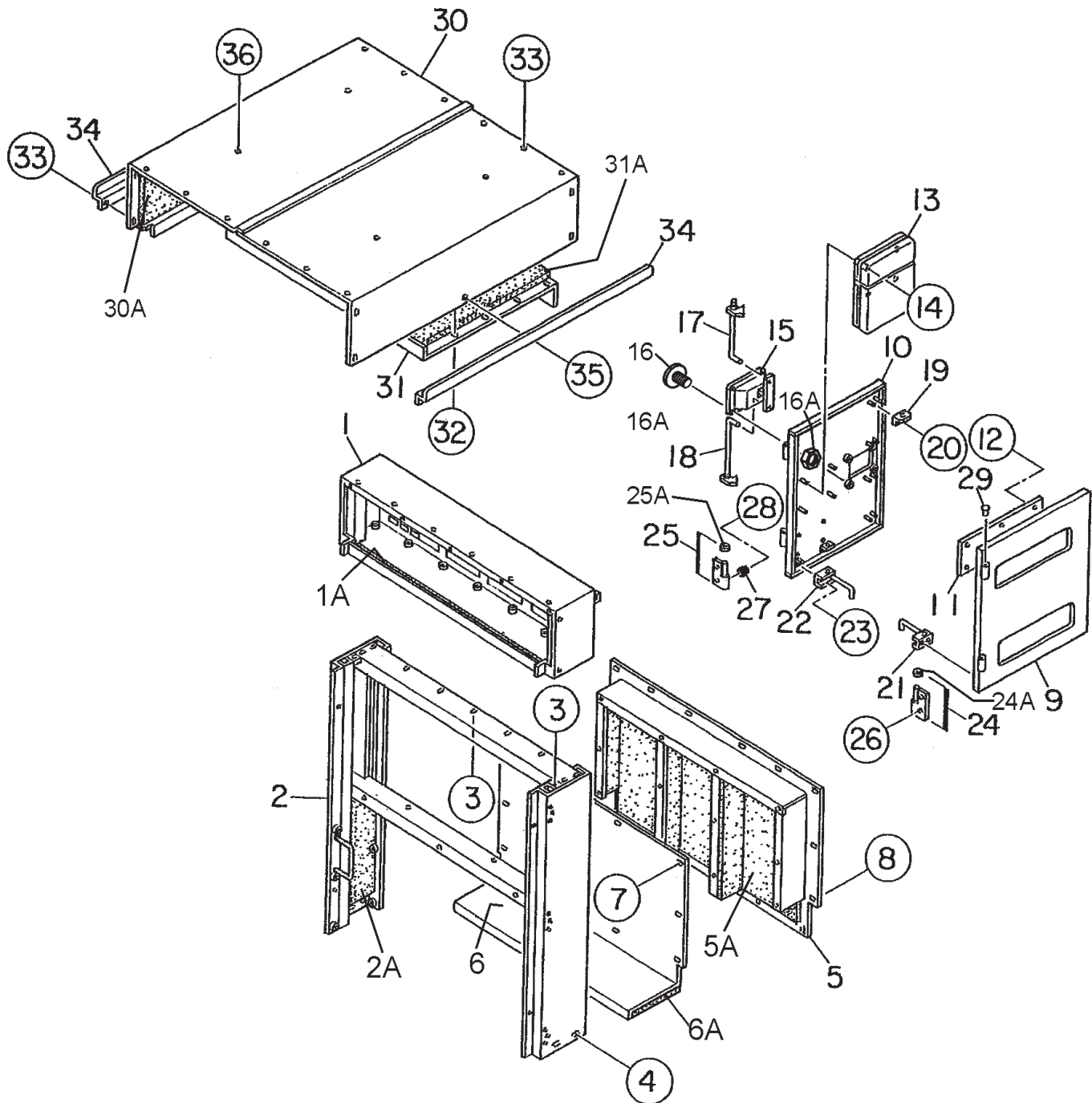

THE PART NUMBER INDICATED IS ORANGE. PLEASE ADD THE FOLLOWING LETTERS WHEN ORDERING COLOR OF UNIT:

MQW-WHITE

THE SERIAL NUMBER MAY BE REQUIRED.

## ENCLOSURE #2 ASSY.

<u>NO.</u>	<u>PART NO.</u>	<u>PART NAME</u>	<u>QTY.</u>	<u>REMARKS</u>
1	C3443000403	REAR FRAME	1	
1A	0228901290	RUBBER SEAL	1	
2	C3443000502	REAR FRAME	1	
2A	8225940104	LINING	1	
3	0017108020	HEX HEAD BOLT	11	
4	0019210025	HEX HEAD BOLT	4	
5	C3443302103	REAR FRAME COVER	1	
5A	C3493300004	LINING	1	
6	C3444302504	DUCT COVER	1	
6A	C3491400004	LINING	1	
7	0017108020	HEX HEAD BOLT	12	
8	0019208020	HEX HEAD BOLT	15	
9	C3443201303	REAR DOOR FRAME	1	
10	C3443201403	REAR DOOR FRAME	1	
11	8225147004	WINDOW PLATE	2	
12	0207306000	HEX NUT	12	
13	0600800320	MANUAL PAK.....	1.....	9000-07
14	0207006000	HEX NUT	4	
15	B9114000102	DOOR HANDLE	1	
16	0021806015	MACHINE SCREW	4	
16A	0030006000	HEX NUT	4	
17	8225146204	DOOR ROD	1	
18	8225146304	DOOR ROD	1	
19	0845050704	STAY	4	
20	0207006000	HEX NUT	8	
21	0805011304	DOOR STOPPER	1	
22	0805011204	DOOR STOPPER	1	
23	0207006000	HEX NUT	4	
24	0845047104	HINGE	2	
24A	0845045004	WASHER	2	
25	0845047204	HINGE	2	
25A	0845045004	WASHER	2	
26	0019208020	HEX HEAD BOLT	6	
27	0601850097	STOPPER	2	
28	0025408025	MACHINE SCREW	2	
29	0845031504	CAP	4	
30	C3463201202	ROOF PANEL	1	
30A	C3493500304	LINING	1	
31	C3464501704	ROOF PANEL COVER	1	
31A	C3494502204	LINING	1	
32	0017108020	HEX HEAD BOLT	15	
33	0019208020	HEX HEAD BOLT	20	
34	C3463500304	GUTTER	2	
35	0092108020	HEX HEAD BOLT	2	
36	0019210025	HEX HEAD BOLT	4	



**ENCLOSURE #3 ASSY.**

---

<b>NO.</b>	<b>PART NO.</b>	<b>PART NAME</b>	<b>QTY.</b>	<b>REMARKS</b>
1	C3453200702	SPLASHER PANEL	1	
1A	C3493402104	LINING	1	
2	0019108065	HEX HEAD BOLT	6	
2A	0042308000	WASHER, LOCK	6	
2B	0042408000	WASHER, FLAT	6	
3	C3453100503	SIDE PANEL	1	
3A	C3493401004	LINING	1	
4	C3453100603	SIDE PANEL	1	
4A	C3493401104	LINING	1	
5	0019108065	HEX HEAD BOLT	10	
5A	0042308000	WASHER, LOCK	10	
5B	0042408000	WASHER, FLAT	10	
6	C3453100703	SIDE PANEL	1	
6A	C3493401204	LINING	1	
7	C3453100803	SIDE PANEL	1	
7A	C3493401304	LINING	1	
8	C3453300504	DUCT	1	
8A	C3493401803	LINING	1	
9	C3453300604	DUCT	1	
9A	C3493401903	LINING	1	
10	C3453300704	DUCT	1	
10A	C3493402003	LINING	1	
11	0207006000	HEX NUT	21	
12	C3453000903	SIDE PANEL	1	
12A	C3493400604	LINING	1	
13	C3453001003	SIDE PANEL	1	
13A	C3493400704	LINING	1	
14	C3453001103	SIDE PANEL	1	
14A	C3493400804	LINING	1	
15	C3453005203	SIDE PANEL	1	
15A	C3493400904	LINING	1	
16	C3453300304	DUCT	1	
16A	C3493401603	LINING	1	
17	C3453300804	DUCT	1	
17A	C3493402203	LINING	1	
18	C3453300404	DUCT	1	
18A	C3493401704	LINING	1	
19	C3453500004	PANEL	1	
19A	C3493401704	LINING	1	
20	0019208016	HEX HEAD BOLT	4	
21	0207006000	HEX NUT	10	
22	B9114000002	DOOR HANDLE	4	
23	0825007362	DOOR HANDLE	3	
24	0021806015	MACHINE SCREW	28	
24A	0030006000	HEX NUT	28	





## **ENCLOSURE #3 ASSY. (CONTINUED)**

---

<b><u>NO.</u></b>	<b><u>PART NO.</u></b>	<b><u>PART NAME</u></b>	<b><u>QTY.</u></b>	<b><u>REMARKS</u></b>
25	0845046904	HINGE	8	
25A	0845045004	WASHER	8	
26	0845047005	HINGE	8	
26A	0845045004	WASHER	8	
27	0019208020	HEX HEAD BOLT	37	
28	0601850097	STOPPER	11	
29	0025408025	MACHINE SCREW	11	
30	0845031504	CAP	16	
31	0019108065	HEX HEAD BOLT	4	
31A	042308000	WASHER, LOCK	4	
31B	0042408000	WASHER, FLAT	4	

# RUBBER SEALS ASSY.

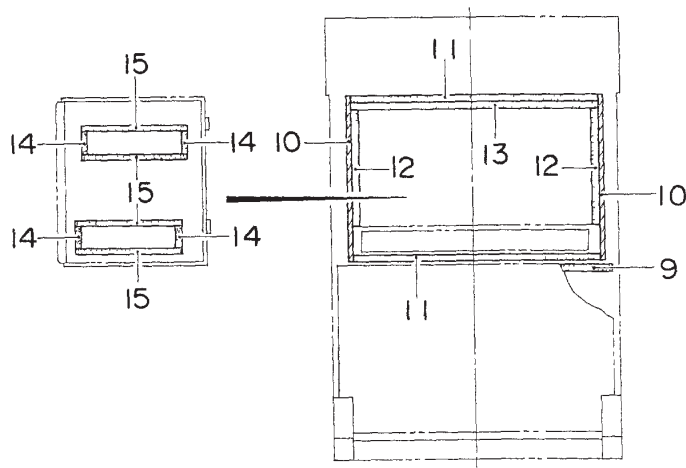
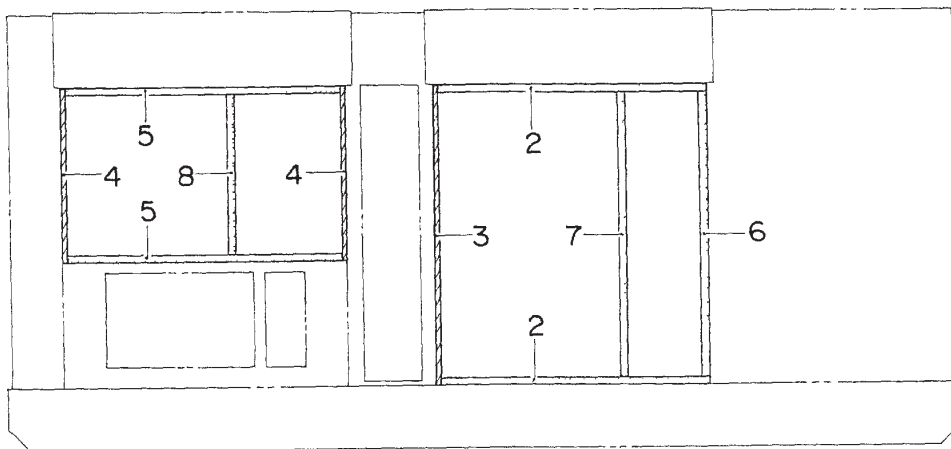
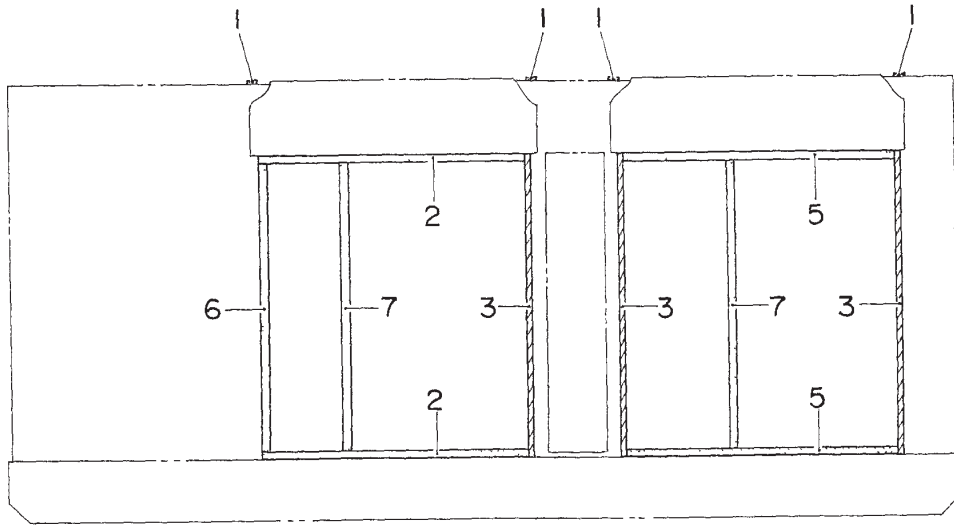

## RUBBER SEALS ASSY.

---

<u>NO.</u>	<u>PART NO.</u>	<u>PART NAME</u>	<u>QTY.</u>	<u>REMARKS</u>
1	0229201400	RUBBER SEAL	4	
2	0228901320	RUBBER SEAL	4	
3	0228901450	RUBBER SEAL	4	
4	0228900850	RUBBER SEAL	2	
5	0228901350	RUBBER SEAL	4	
6	0228801390	RUBBER SEAL	2	
7	0228901390	RUBBER SEAL	3	
8	0228900790	RUBBER SEAL	1	
9	0229201340	RUBBER SEAL	1	
10	0221200795	RUBBER SEAL	2	
11	0228801250	RUBBER SEAL	2	
12	0229200560	RUBBER SEAL	2	
13	0229201230	RUBBER SEAL	1	
14	0228100120	RUBBER SEAL	4	
15	0228100510	RUBBER SEAL	4	

# NAMEPLATE AND DECALS ASSY.

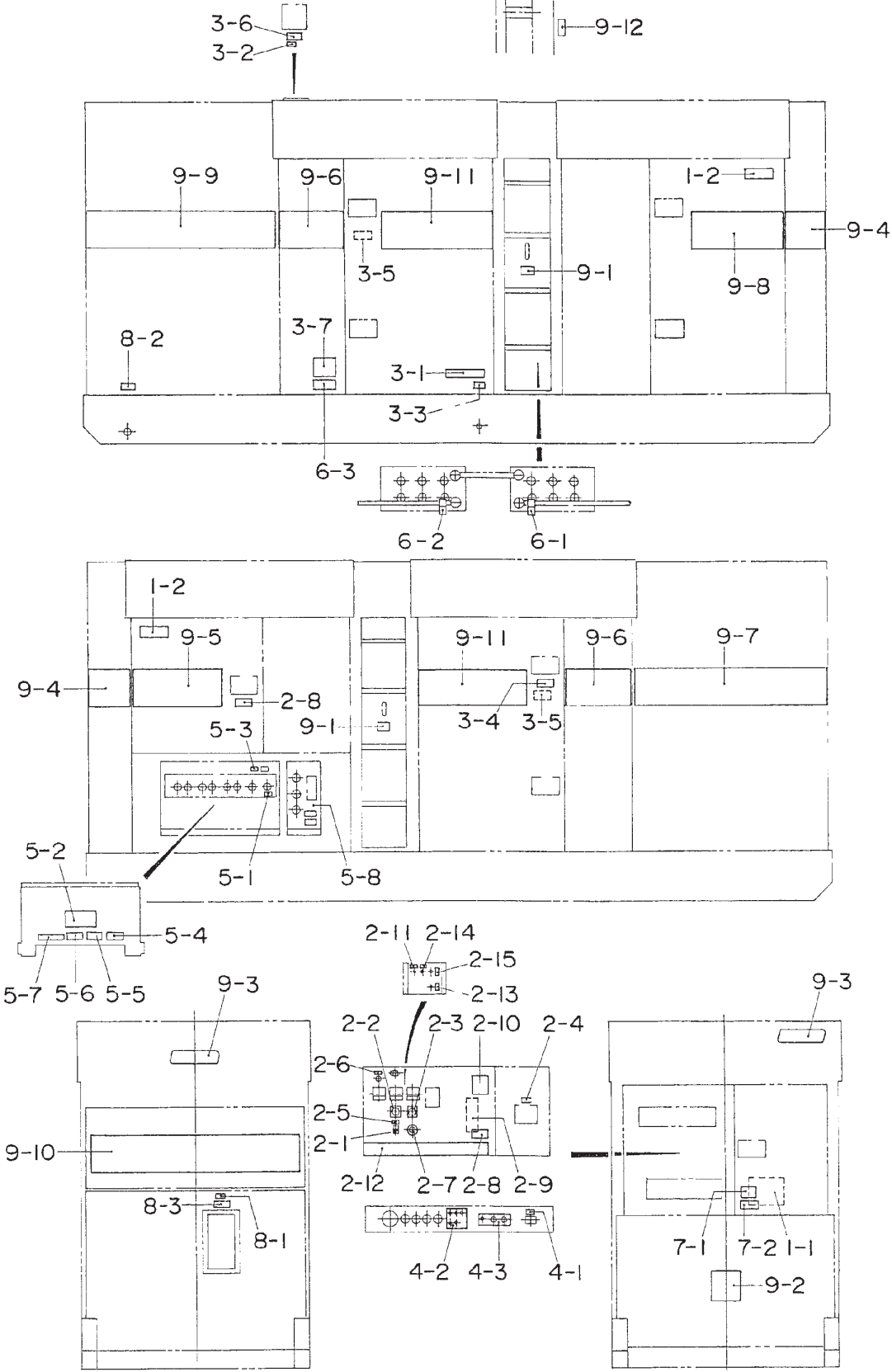

## NAMEPLATE AND DECALS ASSY.

<b>NO.</b>	<b>PART NO.</b>	<b>PART NAME</b>	<b>QTY.</b>	<b>REMARKS</b>
1-1	C3550000703	DECAL : HANDLING PROCEDURES .....	1 .....	C35000070
1-2	C9522100003	DECAL : CAUTION .....	2 .....	C92210000
<b>CONTROL BOX GROUP</b>				
2-1	0800520100	PLATE : ON - OFF .....	1 .....	AT- 202
2-2	0800520904	PLATE : AMMETER CHANGE- OVER SWITCH.....	1 .....	N-2438
2-3	0800520814	PLATE : VOLTMETER CHANGE- OVER SWITCH.....	1 .....	N-2439
2-4	0840624504	DECAL : CIRCUIT BREAKER.....	1 .....	S-3031
2-5	0840624604	DECAL : PANEL LIGHT SWITCH .....	1 .....	S-3032
2-6	0840624704	DECAL : PILOT LAMP .....	1 .....	S-3033
2-7	0840624804	DECAL : VOLTAGE REGULATOR .....	1 .....	S-3034
2-8	B9531100604	DECAL : WARNING ELECTRIC SHOCK HAZARD .....	2 .....	B93110060
2-9	C0551000903	DECAL : SETTING FOR OUTPUT VOLTAGE .....	1 .....	C05100090
2-10	C2551000004	DECAL : SAFETY INSTRUCTIONS.....	1 .....	C25100000
2-11	C3551001004	DECAL : DIAGNOSTIC LAMP .....	1 .....	C35100100
2-12	C3560100003	DECAL : WHISPERWATT 400 .....	1 .....	C36010000
2-13	C9500402104	DECAL : HIGH IDLE SPEED .....	1 .....	C90040210
2-14	C9520027704	DECAL : DIAGNOSTIC BUTTON .....	1 .....	C92002770
2-15	C9521007504	DECAL : DIAGNOSTIC SWITCH .....	1 .....	C92100750
<b>ENGINE &amp; RADIATOR GROUP</b>				
3-1	1320610603	DECAL : WATER- OIL .....	1 .....	S-1760
3-2	6360610304	DECAL : WATER .....	1 .....	S-1880
3-3	6360620204	DECAL : OIL DRAIN PLUG.....	1 .....	S-1885
3-4	B9504000304	DECAL : CAUTION HOT PARTS.....	1 .....	B90400030
3-5	B9504000404	DECAL : WARNING MOVING PARTS.....	2 .....	B90400040
3-6	B9504100104	DECAL : WARNING HOT COOLANT.....	1 .....	B90410010
3-7	C3550000603	DECAL : AIR BLEEDING PROCEDURE .....	1 .....	C35000060
<b>ENGINE OPERATING PANEL GROUP</b>				
4-1	C0551000504	DECAL : BATTERY SWITCH .....	1 .....	C05100050
4-2	C3550000404	DECAL : ALARM LAMP .....	1 .....	C35000040
4-3	C3550000503	DECAL : OPERATING PANEL .....	1 .....	C35000050
<b>OUTPUT TERMINAL GROUP</b>				
5-1	0840614104	DECAL : GROUND .....	1 .....	S-2635
5-2	0840619904	DECAL : DANGER HIGH VOLTAGE.....	1 .....	S-2731
5-3	9039209064	DECAL : START CONTACT .....	1 .....	S-4468
5-4	B9511100304	DECAL : WARNING .....	1 .....	B91110030
5-5	B9511100404	DECAL : WARNING ELECTRIC SHOCK HAZARD .....	1 .....	B91110040
5-6	B9531100504	DECAL : WARNING ELECTRIC SHOCK HAZARD .....	1 .....	B93110050
5-7	C0551000404	DECAL : 3- PHASE OUTPUT TERMINAL .....	1 .....	C05100040
5-8	C1551000803	DECAL : RECEPTACLE & CIRCUIT BREAKER.....	1 .....	C15100080

# NAMEPLATE AND DECALS ASSY. (CONTINUED)

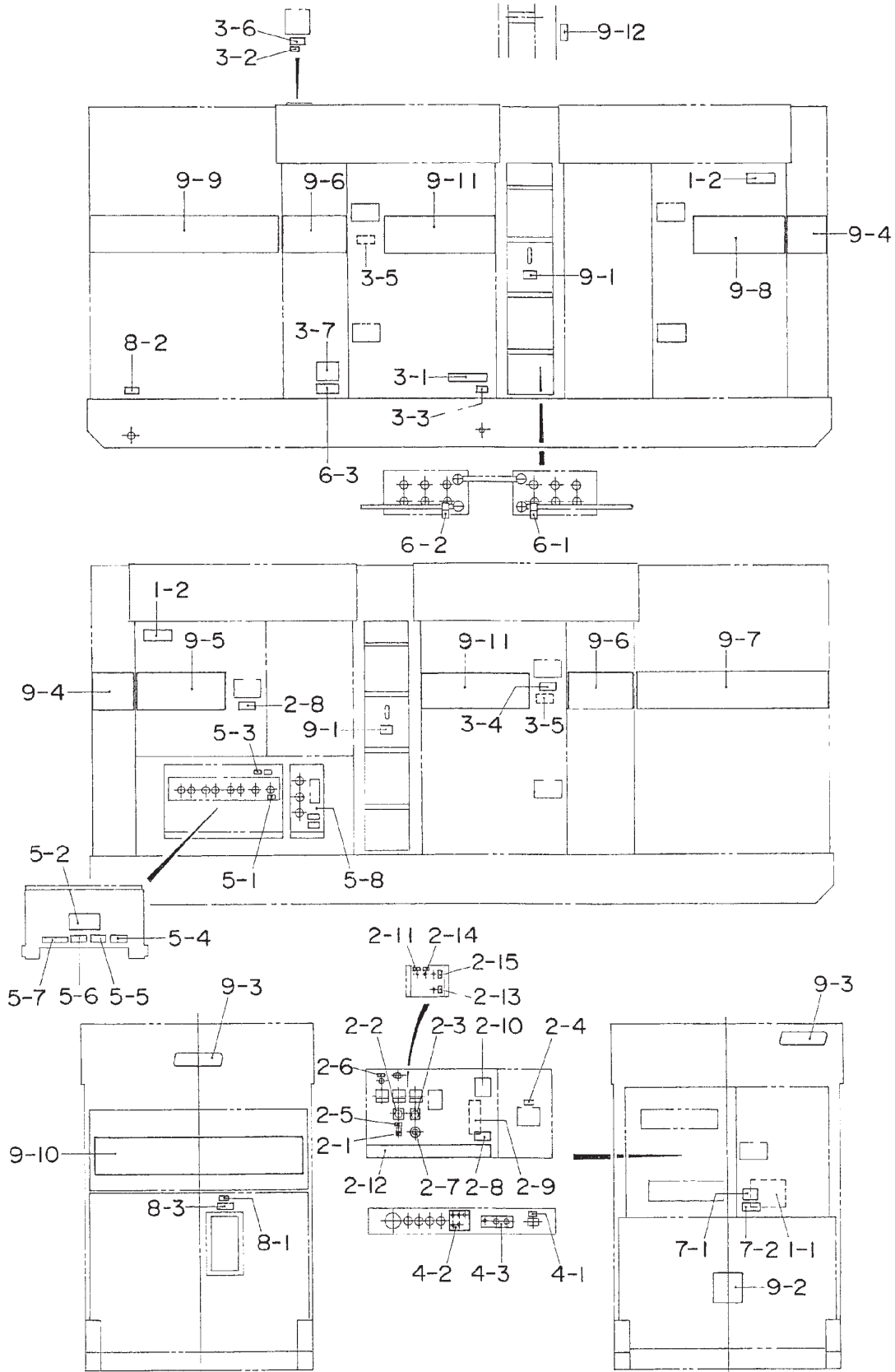

## NAMEPLATE AND DECALS ASSY. (CONTINUED)

<u>NO.</u>	<u>PART NO.</u>	<u>PART NAME</u>	<u>QTY.</u>	<u>REMARKS</u>
BATTERY GROUP				
6-1	0800689404	DECAL : + .....	1.....	S-2090
6-2	0800689504	DECAL : - .....	1.....	S-2091
6-3	C9505300004	DECAL : CAUTION .....	1.....	C90530000
MUFFLER GROUP				
7-1	A9504000014	DECAL : DANGER .....	1.....	A90400001
7-2	B9504200004	DECAL : WARNING ENGINE EXHAUST .....	1.....	B90420000
FUEL TANK GROUP				
8-1	1320620904	DECAL : DIESEL FUEL .....	1.....	S-1756
8-2	6360620004	DECAL : FUEL DRAIN PLUG .....	1.....	S-1883
8-3	B9504500004	DECAL : WARNING DIESEL FUEL .....	1.....	B9045 000
BONNET GROUP				
9-1	1320621504	DECAL : SUPPORT HOOK .....	1.....	S-2257
9-2	0840625902	DECAL : MQ.....	1.....	S-3057
9-3	0600500090	EMBLEM	2	
9-3A	0021106016	MACHINE SCREW	4	
9-4	C2561101204	STRIPE	2	
9-5	C3561100203	STRIPE	1	
9-6	C4561102204	STRIPE	2	
9-7	C3561101603	STRIPE	1	
9-8	C3561100803	STRIPE	1	
9-9	C3561101703	STRIPE	1	
9-10	C3561101003	STRIPE	1	
9-11	C5561100204	STRIPE	2	
9-12	C9504000304	DECAL : CAUTION .....	1.....	C90400030

# TERMS AND CONDITIONS OF SALE — PARTS

## PAYMENT TERMS

Terms of payment for parts are net 30 days.

## FREIGHT POLICY

All parts orders will be shipped collect or prepaid with the charges added to the invoice. All shipments are F.O.B. point of origin. Multiquip's responsibility ceases when a signed manifest has been obtained from the carrier, and any claim for shortage or damage must be settled between the consignee and the carrier.

## MINIMUM ORDER

The minimum charge for orders from Multiquip is \$15.00 net. Customers will be asked for instructions regarding handling of orders not meeting this requirement.

## RETURNED GOODS POLICY

Return shipments will be accepted and credit will be allowed, subject to the following provisions:

1. A Returned Material Authorization must be approved by Multiquip prior to shipment.
2. To obtain a Return Material Authorization, a list must be provided to Multiquip Parts Sales that defines item numbers, quantities, and descriptions of the items to be returned.
  - a. The parts numbers and descriptions must match the current parts price list.
  - b. The list must be typed or computer generated.
  - c. The list must state the reason(s) for the return.
  - d. The list must reference the sales order(s) or invoice(s) under which the items were originally purchased.
  - e. The list must include the name and phone number of the person requesting the RMA.
3. A copy of the Return Material Authorization must accompany the return shipment.
4. Freight is at the sender's expense. All parts must be returned freight prepaid to Multiquip's designated receiving point.

5. Parts must be in new and resalable condition, in the original Multiquip package (if any), and with Multiquip part numbers clearly marked.
6. The following items are not returnable:
  - a. Obsolete parts. (If an item is in the price book and shows as being replaced by another item, it is obsolete.)
  - b. Any parts with a limited shelf life (such as gaskets, seals, "O" rings, and other rubber parts) that were purchased more than six months prior to the return date.
  - c. Any line item with an extended dealer net price of less than \$5.00.
  - d. Special order items.
  - e. Electrical components.
  - f. Paint, chemicals, and lubricants.
  - g. Decals and paper products.
  - h. Items purchased in kits.
7. The sender will be notified of any material received that is not acceptable.
8. Such material will be held for five working days from notification, pending instructions. If a reply is not received within five days, the material will be returned to the sender at his expense.
9. Credit on returned parts will be issued at dealer net price at time of the original purchase, less a 15% restocking charge.
10. In cases where an item is accepted, for which the original purchase document can not be determined, the price will be based on the list price that was effective twelve months prior to the RMA date.
11. Credit issued will be applied to future purchases only.

## PRICING AND REBATES

Prices are subject to change without prior notice. Price changes are effective on a specific date and all orders received on or after that date will be billed at the revised price. Rebates for price declines and added charges for price increases will not be made for stock on hand at the time of any price change.

Multiquip reserves the right to quote and sell direct to Government agencies, and to Original Equipment Manufacturer accounts who use our products as integral parts of their own products.

## SPECIAL EXPEDITING SERVICE

A \$35.00 surcharge will be added to the invoice for special handling including bus shipments, insured parcel post or in cases where Multiquip must personally deliver the parts to the carrier.

## LIMITATIONS OF SELLER'S LIABILITY

Multiquip shall not be liable hereunder for damages in excess of the purchase price of the item with respect to which damages are claimed, and in no event shall Multiquip be liable for loss of profit or good will or for any other special, consequential or incidental damages.

## LIMITATION OF WARRANTIES

No warranties, express or implied, are made in connection with the sale of parts or trade accessories nor as to any engine not manufactured by Multiquip. Such warranties made in connection with the sale of new, complete units are made exclusively by a statement of warranty packaged with such units, and Multiquip neither assumes nor authorizes any person to assume for it any other obligation or liability whatever in connection with the sale of its products. Apart from such written statement of warranty, there are no warranties, express, implied or statutory, which extend beyond the description of the products on the face hereof.

Effective: February 22, 2006





# OPERATION AND PARTS MANUAL

## HERE'S HOW TO GET HELP

PLEASE HAVE THE MODEL AND SERIAL  
NUMBER ON-HAND WHEN CALLING

### ***MQ Power***

1800 Water Ridge Rd.    Tel. (800) 883-2551  
Suite 500/600            Fax (972) 315-1847  
Lewisville, TX 75057  
Contact: [mqpower@multiquip.com](mailto:mqpower@multiquip.com)  
Web: [www.mqpower.com](http://www.mqpower.com)

### ***MQ Parts Department***

800-427-1244            Fax: 800-672-7877  
310-537-3700            Fax: 310-637-3284

### ***Service/Tech Support/Warranty***

800-835-2551            Fax: 310-638-8046

© COPYRIGHT 2008, MULTIQUIP INC.

MQ Power and the MQ Power logo are registered trademarks of Multiquip Inc. and may not be used, reproduced, or altered without written permission. All other trademarks are the property of their respective owners and used with permission.

This manual MUST accompany the equipment at all times. This manual is considered a permanent part of the equipment and should remain with the unit if resold.

The information and specifications included in this publication were in effect at the time of approval for printing. Illustrations, descriptions, references and technical data contained in this manual are for guidance only and may not be considered as binding. Multiquip Inc. reserves the right to discontinue or change specifications, design or the information published in this publication at any time without notice and without incurring any obligations.

Your Local Dealer is:

